

Kits & Parts for Set Up & Cleaning

Dispensers & Related Equipment

Version 7.4
July 7, 2022
Part No. 22290036

NOTE:

This is a generic set of most kits available.



prepared by GPD Global® Documentation Department



611 Hollingsworth Street
Grand Junction, CO, USA 81505
tel: +1.970.245-0408 fax: +1.970.245-9674
request@gpd-global.com www.gpd-global.com
Copyright 2022© GPD Global® All Rights Reserved

Contents

Machines

- [DS Series, Level 1 - 22110015C \(Systems as of Dec 2016\)](#) (pg 1)
- [DS Series, Level 1 - 22110015B \(Systems prior to Dec 2016\)](#) (pg 2)
- [MAX Series Spare Parts Kit - 22290174](#) (pg 38)
- [MAX Series Spare Parts Kit \(Legacy\) - 22290005](#) (pg 32)
- [MAX Series, Level 1 \(Legacy\) - 22290005A](#) (pg 30)
- [MAX Series, Level 2 \(Legacy\) - 22290005B](#) (pg 31)

Devices

- [Calibration Station Parts List - 22200618](#) (pg 28)
- [Calibration Station Spare Parts - Ceramic - 22295043-0001](#) (pg 44)
- [ClearVU Vision Focus Tool - 22295104](#) (pg 46)
- [Conveyor, DS Series - 22164101A](#) (pg 27)
- [Conveyor, MAX Series - 22290010](#) (pg 33)
- [Fluid Pressure Sensor Calibration Kit - 22893033](#) (pg 50)
- [Gantry Lubrication Kit - 22294003](#) (pg 43)
- [Needle Cleaner, Grip - 22150521](#) (pg 26)
- [Needle Cleaner, Grip Multiwipe - 22290034](#) (pg 34)
- [Needle Cleaner, Grip Synthetic - 22295111](#) (pg 47)
- [Needle Cleaner Wipe \(Pad Type\) Assembly Kit - 22295088](#) (pg 45)
- [Precision Fixture Setup - 22295560](#) (pg 48)
- [Scale Weight Kit - 22213013](#) (pg 29)
- [Taper Lock Setup Leveling - 22110142](#) (pg 5)
- [Taper Lock Setup Leveling \(Extended Pin\) - 22110142-0001](#) (pg 6)
- [Taper Lock Setup Leveling \(Fixed Mount\) - 22110142-0002](#) (pg 7)
- [Taper Lock Setup Leveling \(Tilt Head\) - 22110142-0003](#) (pg 8)

Valves / Pumps

- [HyFlo Pump Support Kit - 22142002](#) (pg 20)
- [LX Auger Valve - 22110073](#) (pg 3)
- [LX Auger Valve Maintenance - 22110102](#) (pg 4)
- [LX Auger Cartridge - 22110398](#) (pg 9)
- [Micro-Dot Support Cleaning Kit - 22141031](#) (pg 16)
- [Micro-Dot No Drip Kit - 22141047](#) (pg 18)
- [NCM Pump Support Kit - 22110462](#) (pg 10)
- [NCM Wipe Replacement Kit - 22295608](#) (pg 49)
- [NCM5000 Pump Cleaning Kit - 22142049](#) ([pg 21](#))
- [NCM5000 Pump Cleaning Kit - 22142050](#) ([pg 21](#))
- [NCM5000 Pump Cleaning Kit - 22142051](#) (pg 21)
- [NCM5000 Pump Cleaning Kit - 22142052](#) ([pg 21](#))
- [NCM5000 Pump Heater Repair Kit - 22293252](#) (pg 40)
- [NCM5000 Pump Maintenance Kit \(Cross Seal\) - 22293343](#) (pg 42)
- [NCM5000 Pump Maintenance Kit \(Legacy\) - 22290043](#) (pg 36)
- [NCM5000 Pump Maintenance Tool Kit - 22290042](#) (pg 35)
- [NCM8350 Pump Cleaning Kit - 22293137](#) (pg 39)
- [PCD Pump Series Cleaning Kit - 22110467](#) (pg 11)
- [PCD 2-Part Mixing Pump Cleaning Kit - 22110493-0001](#) (pg 14)
- [PCD Micro Pump Support Kit - 22290172](#) (pg 37)
- [Precision Auger Pump Support Kit \(186\) - 22142053](#) (pg 22)
- [Precision Auger Pump Support Kit \(105 / 062\) - 22142054](#) (pg 23)
- [Precision Needle Cleaning Kit - 22141032](#) (pg 17)
- [Pump Luer \(062-105\) Support Kit - 22141056](#) (pg 19)
- [Pump Luer \(186\) Support Kit - 22142071](#) (pg 24)
- [Pump Luer Legacy Support Kit - 22144014](#) (pg 25)
- [Stamping Tool Indicator Alignment Kit - 22293266](#) (pg 41)
- [Time Pressure Syringe Mount Kit - 22110504](#) (pg 15)

NOTE: The following pages are arranged in numeric order (by Part Number).

DS Series, Level 1 - 22110015C (Systems as of Dec 2016)

Revision Notes
A Original issue.

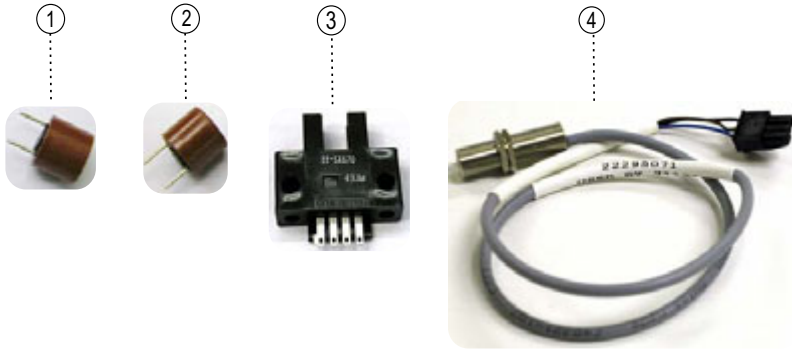

Item	Description	Part No.	Qty.
1	Fuse, 2 amp, 250 V	4300-0045	15
2	Fuse, 6.3 amp, 250 V	4300-0046	5
3	Opto switch, NC/NO	10/0221	2
4	Switch, ultra precision	22295071	1
5	Pipette, fine tip	10/3303	5
6	Touch probe tip DS04	22121310	1
7	Grease, AS2 (0.80 g)	10/3207	1
8	Valve, solenoid, 5 port	10/1622	1
9	Lamp, 11 amp, 24 V	10/2294	5
10	Safety board (PCB)	2200-0446	1

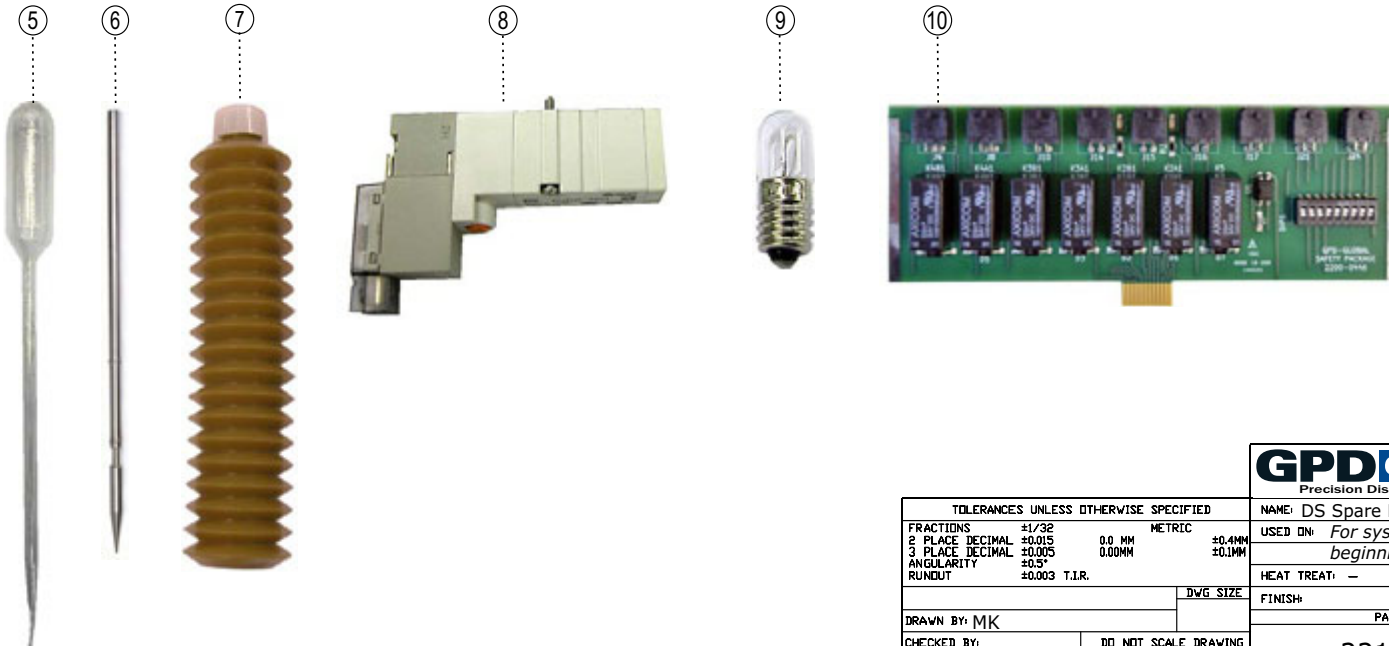

TOLERANCES UNLESS OTHERWISE SPECIFIED			
FRACTIONS	±1/32	METRIC	
2 PLACE DECIMAL	±0.015	0.0 MM	±0.4MM
3 PLACE DECIMAL	±0.005	0.00MM	±0.1MM
ANGULARITY	±0.5°		
RUNDOUT	±0.003 T.I.R.		

GPD Global Precision Dispensing Systems	
NAME: DS Spare Parts Kit - Level 1	
USED ON: For systems as of Dec 2, 2016 beginning with SN 2210171	
HEAT TREAT: -	
FINISH: -	
DWG SIZE	PART NUMBER
REV	
22110015C	
A	

DRAWN BY: MK	DO NOT SCALE DRAWING
CHECKED BY:	SCALE: N/A
DATE: 10/19/18	

DS Series, Level 1 - 22110015B (Systems prior to Dec 2016)









Revision Notes

- A Original issue.
- B Touch probe tip 22121310 replaces 22120999;
- Opto switch 3700-0025 replaces 3700-0029.
- C Add Opto switch 3700-0101.
- D Grease 10/3207 replaces Teflon gel 10/2204.
- E Identification correction for item 12 & Fuse, Time Delay

Item	Description	Part No.	Qty.
1	Valve, solenoid, 5 port	10/1622	1
2	Opto switch, NC/NO	3700-0025	1
3	Opto switch, NC/NO	10/0221	2
4	Opto switch, NC/NO	3700-0101	1
5	Touch probe tip DS04	22121310	1
6	Lamp, 11 amp, 24 V	10/2294	5
7	Fuse, 6.3 amp, 250 V	4300-0046	5
8	Fuse, 15 amp, 250 V	4300-0069	10
9	Fuse, 1.25 amp, 250 V	4300-0073	15
10	Fuse, 8 amp	4300-0049	5
11	Fuse, 2 amp, 250 V	4300-0045	15
12	Relay, 24 VDC, 4-pole	4500-0013	1
13	Grease, AS2 (0.80 g)	10/3207	1
14	Encoder	5500-0019	1
15	Bellows coupler	10/1595	1
16	Encoder	5500-0018	1
17	Relay, 16 amp, 600 V	10/1699	1
18	Pipette, fine tip	10/3303	5
19	Switch, ultra precision	5100-0099	1
NS	Fuse, 3.15 amp, 250 V	10/1702	5
NS	Fuse, time delay	4300-0087	5

NS = not shown



TOLERANCES UNLESS OTHERWISE SPECIFIED		NAME: DS Spare Parts Kit - Level 1	
FRACTIONS	±1/32	METRIC	USED ON: For systems prior to Dec 2016
2 PLACE DECIMAL	±0.015	0.0 MM	and prior to SN 2210171
3 PLACE DECIMAL	±0.005	0.00MM	HEAT TREAT: -
ANGULARITY	±0.5°		FINISH: -
RUNOUT	±0.003 T.I.R.		
		DWG SIZE	PART NUMBER
DRAWN BY: MK			22110015B
CHECKED BY:	DO NOT SCALE DRAWING		REV
DATE: 10/22/12	SCALE: N/A		E

LX Auger Valve - 22110073

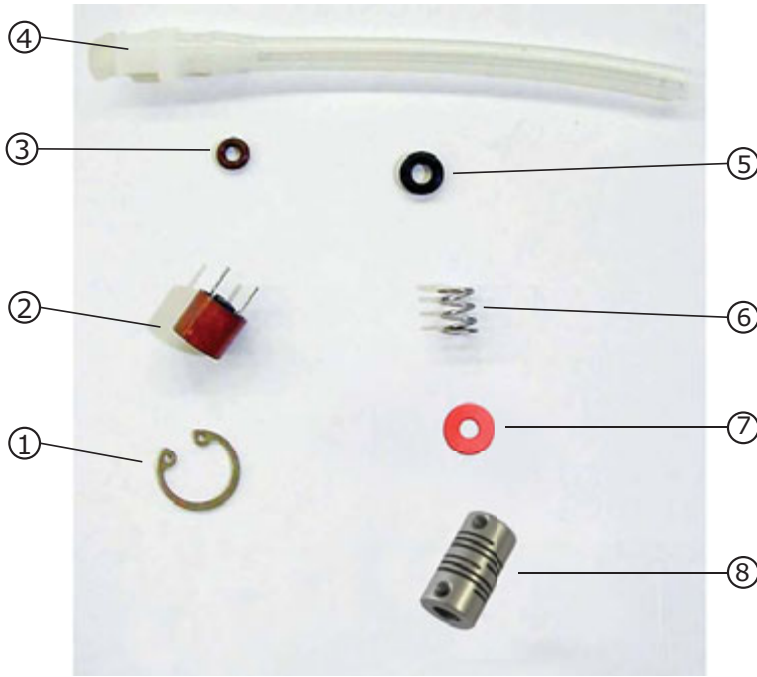

Revision Notes

- 1 Original issue.
- 2 Major changes.
- 3 Delete G3502 and 22110128. Add 22120673 and 22121400.
- 4 Replace 22121400 with 10/4498.

Item	Description	Part No.	Qty
1	Retaining ring	G1037	5
2	Fuse	4300-0102	1
3	O-ring, brown	10/3437	30
4	Reservoir tube	22110064	30
5	O-ring, black	10/3438	30
6	Compression spring	10/3401	5
7	O-ring, red	22120673	2
8	Coupler, beam-type	10/4498	1

TOLERANCES UNLESS OTHERWISE SPECIFIED				GPD Global	
FRACTIONS	±1/32	METRIC		NAME: LX Auger Valve Spare Parts Kit	
2 PLACE DECIMAL	±0.015	0.0 MM	±0.4MM	USED ON:	
3 PLACE DECIMAL	±0.005	0.00MM	±0.1MM	MATERIAL:	
ANGULARITY	±0.5°			HEAT TREAT: --	
RUNDOUT	±0.003 T.I.R.			FINISH:	
DRAWN BY: MK			DWG SIZE:	PART NUMBER	REV
CHECKED BY:		DID NOT SCALE DRAWING		22110073	4
DATE: 02/23/10		SCALE: N/A			

LX Auger Valve Maintenance - 22110102

Revision Notes
 A Original issue.
 B Additional contents; replace image.
 C Major changes to kit contents; replace image.
 D Change 10/4155 quantity from 1 to 3.
 Change 10/4152 quantity from 1 to 2.

Item	Description	Part No.	Qty
1	Gauge Pin, .125 minus	22110392	1
2	Gauge Pin, .0935 minus	22110391	1
3	Collar setup tool	22120638	1
4	Collar setup tool, precision	22121297	1
5	Insertion tool, .091	22120691	1
6	Insertion tool, .125	22120692	1
7	Pipe cleaners	10/3900	1
8	Brush, 5/312	10/4155	3
9	Brush, 3/16	10/4162	1
10	Brush, acid	10/4152	2
11	Snap-ring Pliers	10/4167	1
12	Teflon Lubricant	10/4150	1
13	Luer Wrench	10/3356	1
14	Brush, brass	10/4161	1

TOLERANCES UNLESS OTHERWISE SPECIFIED		GPD Global	
NAME: LX Auger Valve Maintenance Kit		USED ON:	
FRACTIONS	#1/32	METRIC	
6 PLACE DECIMAL	#0.015	0.0 MM	±0.4MM
3 PLACE DECIMAL	#0.005	0.00MM	±0.1MM
ANGULARITY	±0.5°		MATERIAL:
RUNOUT	#0.003 T.I.R.		HEAT TREAT: -
		DWG. SIZE:	FINISH:
DRAWN BY: MK		PART NUMBER	
CHECKED BY:	DO NOT SCALE DRAWING	22110102	
DATE: 02/17/11	SCALE: N/A		REV D

Taper Lock Setup Leveling - 22110142

Revision Notes

A 03/27/2003 Original issue.

B 09/18/2014 Add 22121504, F4552, SACSN2520075.

Item	Description	Part No.	Qty
1	Indicator Gauge	10/1777	1
2	Set Up Level	10/0478	1
3	Taper Lock Calib/Indicator Block	22121037	1
	Alignment Pin, Tapered End	22121504	1
	Washer	F4552	1
	Screw	SACSN2520075	1
4	Instruction Sheet	22110016M	1

TOLERANCES UNLESS OTHERWISE SPECIFIED				NAME: Set Up & Leveling Kit (Taper Lock)	
FRACTIONS	±1/32	METRIC		USED ON:	
2 PLACE DECIMAL	±0.015	0.0 MM	±0.4MM	MATERIAL:	
3 PLACE DECIMAL	±0.005	0.00MM	±0.1MM	HEAT TREAT:	-
ANGULARITY	±0.5°			FINISH:	
RUNDUT	±0.003 T.I.R.				
			DWG SIZE:	PART NUMBER	
DRAWN BY: MK				22110142	
CHECKED BY:		DO NOT SCALE DRAWING		REV	
DATE: 03/27/03		SCALE: N/A		B	

GPD Global

TOLERANCES UNLESS OTHERWISE SPECIFIED				NAME: Set Up & Leveling Kit (Taper Lock)	
FRACTIONS	±1/32	METRIC		USED ON:	
2 PLACE DECIMAL	±0.015	0.0 MM	±0.4MM	MATERIAL:	
3 PLACE DECIMAL	±0.005	0.00MM	±0.1MM	HEAT TREAT:	-
ANGULARITY	±0.5°			FINISH:	
RUNDUT	±0.003 T.I.R.				
			DWG SIZE:	PART NUMBER	
DRAWN BY: MK				22110142	
CHECKED BY:		DO NOT SCALE DRAWING		REV	
DATE: 03/27/03		SCALE: N/A		B	

Taper Lock Setup Leveling (Extended Pin) - 22110142-0001

Revision Notes

A	03/27/2003	Original issue.
B	09/18/2014	Add 22121504, F4552, SACS2520075.

Item	Description	Part No.	Qty
1	Indicator Gauge	10/1777	1
2	Set Up Level	10/0478	1
3	Taper Lock Calib/Indicator Block	22121037	1
	Alignment Pin, Tapered End	22121504	1
	Washer	F4552	1
	Screw	SACS2520075	1
	Screw	SABSN0440025	2
	Pin, Extended	22121689	1
4	Instruction Sheet	22110016M	1

TOLERANCES UNLESS OTHERWISE SPECIFIED				NAME: Set Up & Leveling Kit (Taper Lock)	
FRACTIONS	±1/32	METRIC		USED IN:	Extended Pin version
2 PLACE DECIMAL	±0.015	0.0 MM	±0.4MM	MATERIAL:	
3 PLACE DECIMAL	±0.005	0.00MM	±0.1MM	HEAT TREAT:	-
ANGULARITY	±0.5°			FINISH:	
RUNDOUT	±0.003 T.I.R.				
DRAWN BY: MK				PART NUMBER	
CHECKED BY:				22110142-0001	
DATE: 03/27/03				SCALE: N/A	
					REV
					B

Taper Lock Setup Leveling (Fixed Mount) - 22110142-0002

Revision Notes

A 05/17/2017 Original issue.

Item	Description	Part No.	Qty
1	Indicator Gauge	10/1777	1
2	Set Up Level	10/0478	1
3	Calibration Block	22203759	1
	Alignment Pin, Tapered End	22121504	1
	Washer	F4552	1
	Screw	SACSN2520075	1
4	Instruction Sheet	22110016M	1

TOLERANCES UNLESS OTHERWISE SPECIFIED		NAME: Set Up & Leveling Kit (Taper Lock)	
FRACTIONS	±1/32	METRIC	USED IN: Fixed Mount version
2 PLACE DECIMAL	±0.015	0.0 MM	MATERIAL:
3 PLACE DECIMAL	±0.005	0.00MM	HEAT TREAT: -
ANGULARITY	±0.5°		FINISH:
RUNDOUT	±0.003 T.I.R.	DWG SIZE:	PART NUMBER
DRAWN BY: MK		22110142-0002	
CHECKED BY:		SCALE: N/A	
DATE: 05/17/17		REV: A	

TOLERANCES UNLESS OTHERWISE SPECIFIED		NAME: Set Up & Leveling Kit (Taper Lock)	
FRACTIONS	±1/32	METRIC	USED IN: Fixed Mount version
2 PLACE DECIMAL	±0.015	0.0 MM	MATERIAL:
3 PLACE DECIMAL	±0.005	0.00MM	HEAT TREAT: -
ANGULARITY	±0.5°		FINISH:
RUNDOUT	±0.003 T.I.R.	DWG SIZE:	PART NUMBER
DRAWN BY: MK		22110142-0002	
CHECKED BY:		SCALE: N/A	
DATE: 05/17/17		REV: A	

Taper Lock Setup Leveling (Tilt Head) - 22110142-0003

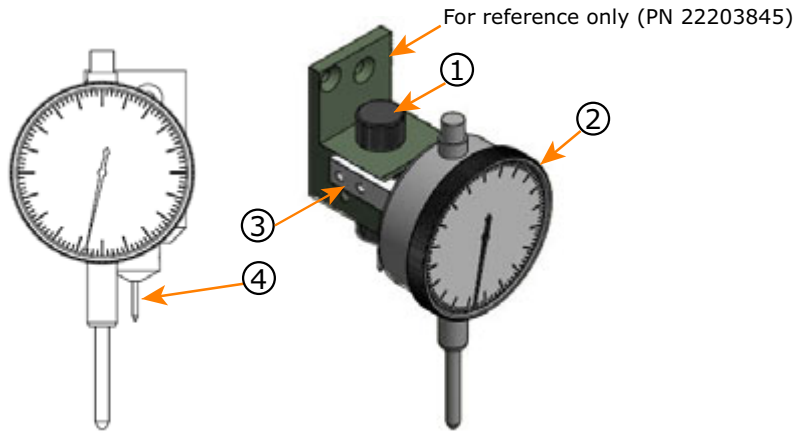

Revision Notes

A 05/25/2021 Original issue.

Item	Description	Part No.	Qty
1	Cartridge Calibration Setup Pin	22203860	1
2	Indicator Gauge	10/1777	1
3	Indicator Adapter Bracket	22203861	1
4	Alignment Pin, Tapered End	22121504	1
5	Washer	F4552	1
6	Screw	SACSN2520075	1
7	Instruction Sheet	22243007	1
8	Set Up Level	10/0478	1



TOLERANCES UNLESS OTHERWISE SPECIFIED				NAME: Set Up & Leveling Kit (Taper Lock)	
FRACTIONS	±1/32	METRIC		USED ON Tilt Head/Precision Auger version	
2 PLACE DECIMAL	±0.015	0.0 MM	±0.4MM	MATERIAL:	
3 PLACE DECIMAL	±0.005	0.00MM	±0.1MM	HEAT TREAT: --	
ANGULARITY	±0.5°			FINISH:	
RUNDOUT	±0.003 T.I.R.	DWG. SIZE:		PART NUMBER	
DRAWN BY: MK		DD NOT SCALE DRAWING		REV	
CHECKED BY:		DATE: 05/25/2021		SCALE: N/A	
				22110142-0003	
				A	

LX Auger Cartridge - 22110398



Style 04 - Size .091 P/N 22110397			
Item	Description	Part No.	Qty
A	Washer	10/4344	2
1	Spring	S2034	2
2	Pipe Cleaners (1 pkg)	10/3900	1
3	O-rings .125	10/4007	1
	O-rings .091	10/3956	11
4	not applicable		
5	Spiral Brush, 5/32	10/4155	3
6	Brass Upright Brush	10/4161	1
7	Acid Brush	10/4152	2
8	N/A		
9	Gauge Pin	22110391	1
10	Teflon Grease	10/4150	1
11	Feed Tubes	22110064	30

Style 04 - Size .125 P/N 22110398			
Item	Description	Part No.	Qty
A	Washer	10/4344	2
1	Spring	S2034	2
2	Pipe Cleaners (1 pkg)	10/3900	1
3	O-rings .125	10/4007	12
4	not applicable		
5	Spiral Brush, 5/32	10/4155	3
6	Brass Upright Brush	10/4161	1
7	Acid Brush	10/4152	2
8	Spiral Brush, 3/16	10/4162	3
9	Gauge Pin	22110392	1
10	Teflon Grease	10/4150	1
11	Feed Tubes	22110064	30

Revision Notes

- 1 Original issue.
- 2 Add p/n 22121400 to kit 22110398.
- 3 Remove p/n 22121400 from kit 22110398.
- 4 Add p/n 10/4344 to both kits: 22110397 and 22110398.

GPD Global

TOLERANCES UNLESS OTHERWISE SPECIFIED				NAME: LX Auger Cartridge Cleaning Kits	
FRACTIONS	1/32	METRIC	0.0 MM	USED IN:	22110397 and 22110398
2 PLACE DECIMAL	±0.015	0.0 MM	±0.1MM	MATERIAL:	
3 PLACE DECIMAL	±0.005	0.000MM	±0.1MM	HEAT TREAT:	-
ANGULARITY	±0.5°			FINISH:	
ROUNDNESS	±0.003 T.I.R.			DRAWN BY:	MK
			DWG SIZE	PART NUMBER	22110398
CHECKED BY:				SCALE:	N/A
DATE:	09/21/11			REV	4

NCM Pump Support Kit - 22110462

7/7/22

Kits & Parts for Dispensers & Related Equipment

10

Revision Notes _____
 A Original issue.

Item	Description	Part No.	Qty
1	Wire Kit, 0.0026	10/4560	1
2	Pathway Cleaners	10/3900	1 pkg
3	Hex Key Wrench, 2 mm	10/4558	1
4	Hex Key Wrench, 2.5 mm	10/4559	1
5	Thread Cleaners	10/3473	1 pkg
6	O-rings, NBR, Metric	10/4547	10
7	Teflon Lubricant, 0.5 oz with MSDS	10/4150	1
8	Opened Wrench, 10 mm	10/4557	1

GPD Global	
NAME: NCM Valve Support Kit	
USED ON:	
MATERIAL:	
HEAT TREAT: -	
FINISH:	
DRAWN BY: MK	PART NUMBER
CHECKED BY:	REV
DATE: 05/03/10	22110462
SCALE: N/A	A

PCD Pump Series Cleaning Kit - 22110467



Revisions

- A 06/16/11 Original issue.
- B 07/24/13 Add 10/4908; change quantity for 10/3206, 10/4775, 10/4878, & 10/4879.
- C 02/04/14 Change quantity for 10/47878, 10/4879.

#	DESCRIPTION	PART NO.	QTY
1	Syringe w/Smooth Piston	10/1512	1
2	Brush, Nylon, 5/16" dia.	10/4908	5
3	Brush, Nylon, 1/2" dia.	10/3206	5
4	Brush, Nylon, 1/4" dia.	10/4775	5
5	Cotton Swab, Sharp Point	10/4878	2 pkg
6	Cotton Swab, Round Point	10/4879	2 pkg
7	Absorbant Thread Cleaner	10/3473	1 pkg
8	Material Pathway Cleaners	10/3900	1 pkg
9	Brush, Bristle Pipe Cleaner	M1001	1 pkg

TOLERANCES UNLESS OTHERWISE SPECIFIED				GPD Global Precision Dispensing Systems	
FRACTIONS	±1/32	METRIC		NAME:	PCD Pump Series Cleaning Kit
6 PLACE DECIMAL	±0.015	0.0 MM	±0.4MM	USED ON:	
3 PLACE DECIMAL	±0.005	0.00MM	±0.1MM	MATERIAL:	
ANGULARITY	±0.5°			HEAT TREAT:	-
RUNDOUT	±0.003 T.I.R.			FINISH:	
DRAWN BY: MK			DWG SIZE:	PART NUMBER	
CHECKED BY:			DO NOT SCALE DRAWING	22110467	
DATE: 06/16/11			SCALE: N/A	REV: C	

PCD3H / PCD3L / PCD3 Pump Cleaning Kit - 22110486



Revisions

- A Original issue.
- B Add 2650-0099. Replace 22110485 with 22110495. Update title/name.
- C Add image of 2650-0099,

#	DESCRIPTION	PART NO.	QTY
1	Syringe w/Smooth Piston	10/1512	1
2	Brush, Nylon, 1/2" dia	10/3206	2
3	Brush, Nylon, 1/4" dia	10/4775	2
4	Material Pathway Cleaners	10/3900	1 pkg
5	Brush, Bristle Pipe Cleaner	M1001	1 pkg
6	Cotton Swab, Sharp Point	10/4878	2 pkg
7	Cotton Swab, Round Point	10/4879	2 pkg
8	Absorbant Thread Cleaner	10/3473	1 pkg
9	Purge Tube Assembly	22110495	10
10	Brush, Nylon, 3/64" dia	2650-0099	2

GPD Global Precision Dispensing Systems	
NAME: PCD3H/PCD3L/PCD3 Pump Cleaning Kit	
USED ON:	
MATERIAL:	
HEAT TREAT: -	
FINISH:	
PART NUMBER	
22110486	
REV	
C	

TOLERANCES UNLESS OTHERWISE SPECIFIED			
FRACTIONS	±1/32	METRIC	
2 PLACE DECIMAL	±0.015	0.0 MM	±0.4MM
3 PLACE DECIMAL	±0.005	0.00MM	±0.1MM
ANGULARITY	±0.5°		
RUNDOUT	±0.003 T.I.R.		
DRAWN BY: MK		DWG SIZE:	
CHECKED BY:		DO NOT SCALE DRAWING	
DATE: 06/16/11		SCALE: N/A	

PCD4H & PCD4L Pump Cleaning Kit - 22110493

Revisions

- A Original issue.
- B Add PCD4L to title block Name.
- C Add 22110485.



#	DESCRIPTION	PART NO.	QTY
1	Syringe w/Smooth Piston	10/1512	1
2	Brush, Nylon, 5/32" dia	10/4155	2
3	Brush, Nylon, 1/4" dia	10/4775	2
4	Material Pathway Cleaners	10/3900	1 pkg
5	Brush, Bristle Pipe Cleaner	M1001	1 pkg
6	Cotton Swab, Sharp Point	10/4878	2 pkg
7	Cotton Swab, Round Point	10/4879	2 pkg
8	Absorbant Thread Cleaner	10/3473	1 pkg
9	Brush, Nylon, 5/16" dia	10/4908	2
10	Brush, Nylon, 3/8" dia	10/4909	2
11	Purge Tube Assembly	22110485	10

GPD Global Precision Dispensing Systems		NAME: PCD4H & PCD4L Pump Cleaning Kit	
TOLERANCES UNLESS OTHERWISE SPECIFIED		USED ON:	
FRACTIONS ±1/32	METRIC	MATERIAL:	
2 PLACE DECIMAL ±0.015	0.0 MM ±0.4MM	HEAT TREAT: -	
3 PLACE DECIMAL ±0.005	0.00MM ±0.1MM	FINISH:	
ANGULARITY ±0.5°		PART NUMBER	
RUNDUT ±0.003 T.I.R.		REV	
DRAWN BY: MK	DWG SIZE:	22110493	
CHECKED BY:	DO NOT SCALE DRAWING	C	
DATE: 06/16/11	SCALE: N/A		

PCD 2-Part Mixing Pump Cleaning Kit - 22110493-0001



Revisions

- A Original issue.
- B Delete 22110485 Purge Tubes.

#	DESCRIPTION	PART NO.	QTY
1	Syringe w/Smooth Piston	10/1512	2
2	Brush, Nylon, 5/32" dia	10/4155	2
3	Brush, Nylon, 1/4" dia	10/4775	2
4	Material Pathway Cleaners	10/3900	1 pkg
5	Brush, Bristle Pipe Cleaner	M1001	1 pkg
6	Cotton Swab, Sharp Point	10/4878	2 pkg
7	Absorbant Thread Cleaner	10/3473	1 pkg
8	Brush, Nylon, 3/8" dia	10/4909	2

TOLERANCES UNLESS OTHERWISE SPECIFIED		GPD Global Precision Dispensing Systems	
FRACTIONS ±1/32 METRIC		NAME: PCD Two-Part Pump Cleaning Kit	
2 PLACE DECIMAL ±0.015 0.0 MM METRIC ±0.4MM		USED ON:	
3 PLACE DECIMAL ±0.003 0.00MM ±0.1MM		MATERIAL:	
ANGULARITY ±0.5°		HEAT TREAT: -	
RUNDOUT ±0.003 T.I.R.		FINISH:	
DRAWN BY: MK		PART NUMBER	
CHECKED BY:		22110493-0001	
DATE: 07/14/17		REV: B	
DO NOT SCALE DRAWING		SCALE: N/A	

Time Pressure Syringe Mount Kit - 22110504

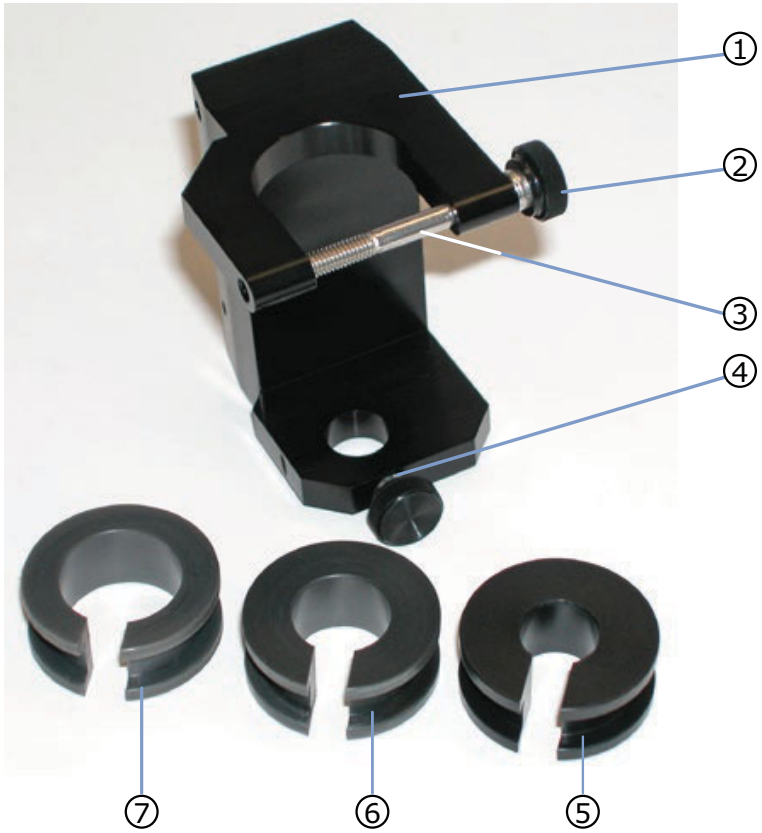

Revision Notes

- A 05/10/12 Original issue.
- B 08/01/12 Adapter 22121627 replaces 22121385; 2400-0028 knobs added.
- C 02/07/13 Revise part numbers for Items 5 and 7.
- D 02/04/14 Replace 22120168, 22120019, 22120020 with 22141041, 22141042, 22141043; correct SACSM040070008 typo.
- E 10/26/15 Revise 22121627 with hole addition.

Item	Description	Part No.	Qty
1	Liquid Dispense Male Adapter	22121627	1
2	Knobs	2400-0028	2
3	Screw, 45 mm	SACSM040070045	1
4	Screw, 8 mm	SACSM040070008	1
5	Syringe Bushing, 3 cc	22141041	1
6	Syringe Bushing, 5 cc	22141042	1
7	Syringe Bushing, 10 cc	22141043	1



TOLERANCES UNLESS OTHERWISE SPECIFIED				NAME: Time Pressure Syringe Mount Kit	
FRACTIONS	#1/32	METRIC		USED ON:	
2 PLACE DECIMAL	±0.05	0.0 MM	±0.4MM	MATERIAL:	
3 PLACE DECIMAL	±0.005	0.00MM	±0.1MM	HEAT TREAT:	-
ANGULARITY	±0.5°			FINISH:	
RUNDOUT	±0.003 T.I.R.				
DRAWN BY: MK			DWG SIZE:	PART NUMBER	REV
CHECKED BY:			DO NOT SCALE DRAWING	22110504	E
DATE: 05/10/12			SCALE: N/A		

Micro-Dot Support Cleaning Kit - 22141031



Needles (various gauges)

Item	Description	Part No.
1	Teflon/Dielectric Grease	10/4767
2	Teflon Oil	10/3432
4	Cotton Swabs	10/3473
5	Pipe Cleaners	10/3900
6	Needle Cleaning Kit Contents*	N/A
7	Pin Vise*	10/4196
8	Syringe & Plunger, 10 cc*	10/4231
9	Tubes with Luer Adapters	22110064
10	Multilens Magnifier*	2725-0029
11	Pilot Cleaning Tool*	22131209H
12	Cleaning Wires*	varies with configuration
13	Magnet*	10/4197
14	Cleaning Brushes	10/4155
15	Spanner Wrench	10/3451
16	Allen Wrench Kit	10/3452
17	Coupling Assembly	10/3660
18	No-Drip Micro-Dot Kit	22141047

*Included only when needles are ordered with kit.

Revision Notes

- F 04/21/10 Update Item 1, PN 10/4150 image & description.
- G 09/17/12 Add Item 17, PN 10/3660.
- H 10/29/12 Add PN 2725-0029 to Item 10.
- I 08/29/13 Add PN 22141047.
- J 04/14/14 Item 1 PN 10/4767 was 10/4150.
- K 09/18/17 Item 3 PN 22140004 removed. Add *note to needle-specific parts.

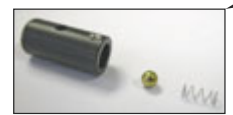

TOLERANCES UNLESS OTHERWISE SPECIFIED				GPD Global Precision Dispensing Systems	
FRACTIONS	±1/32	METRIC		NAME: Micro-Dot Support/Cleaning Kit	
2 PLACE DECIMAL	±0.015	0.0 MM	±0.4MM	USED ON:	
3 PLACE DECIMAL	±0.005	0.00MM	±0.1MM	MATERIAL:	
ANGULARITY	±0.5°			HEAT TREAT: -	
RUNDOUT	±0.003 T.I.R.			FINISH:	
DRAWN BY: MK			PART NUMBER		
CHECKED BY:			22141031		
DATE: 10/29/12			SCALE: N/A		
				REV	
				K	

Precision Needle Cleaning Kit - 22141032



Revisions

- A Original issue.
- B Add cleaning wire kits detail.

ITEM	DESCRIPTION	PART NO.
1	Cleaning Syringe & Plunger (10 cc)	10/4231
2	Pin Vise	10/4196
3	Magnet	10/4197
4	Multi-Lens Magnifier	2725-0029
5	Cleaning Wire Kits	Varies with configuration. Sizes listed below.
6	Pilot Cleaning Tool	22131209H

CLEANING WIRE KITS
 Each kit/set includes 4 tapered-tip wires and 3 scoop-end drill bits for a single gauge.
 18 gauge = 10/4311
 20 gauge = 10/3720
 21 gauge = 10/3721
 22 gauge = 10/3722
 23 gauge = 10/3723
 25 gauge = 10/3725
 27 gauge = 10/3727
 28 gauge = 10/3728
 30 gauge = 10/3730
 31 gauge = 10/3731
 32 gauge = 10/3732

TOLERANCES UNLESS OTHERWISE SPECIFIED			GPD Global Precision Dispensing Systems	
FRACTIONS	±1/32	METRIC	NAME: Precision Needle Cleaning Kit	
6 PLACE DECIMAL	±0.015	0.0 MM	USED ON:	
3 PLACE DECIMAL	±0.005	0.00MM	MATERIAL:	
ANGULARITY	±0.5°		HEAT TREAT: —	
RUNDOUT	±0.003 T.I.R.		FINISH:	
DRAWN BY: MK			PART NUMBER	
CHECKED BY:			22141032	
DATE: 07/15/15			REV: B	
SCALE: N/A				

Micro-Dot No Drip Kit - 22141047

Revision Notes
 A Original issue.

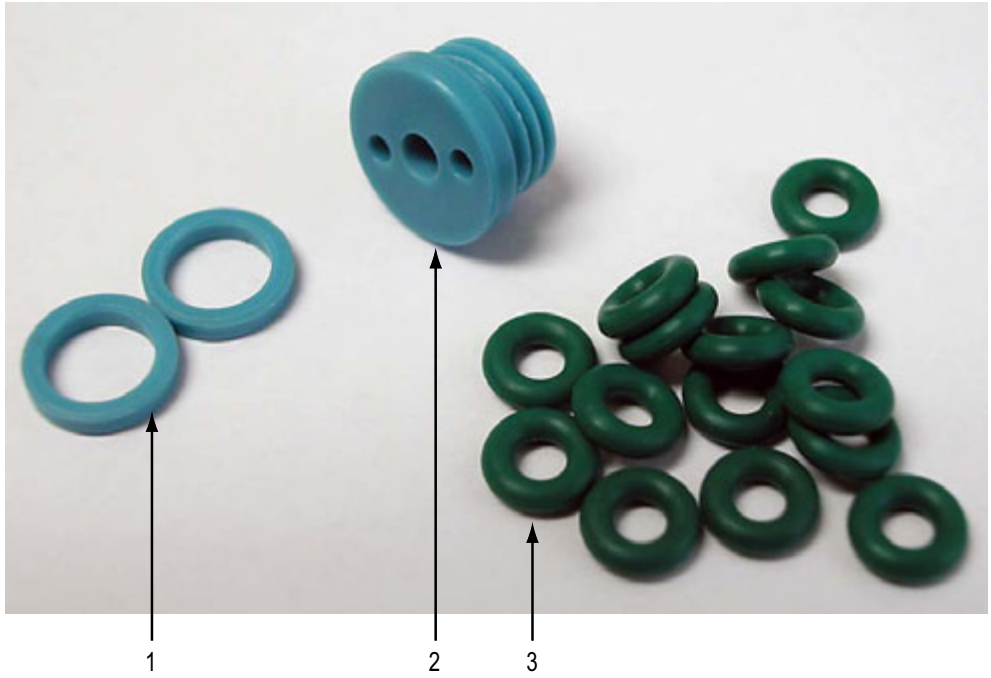

NOTE: Pieces/Parts not sold separately; sold only as a kit.

Item	Description	Qty
1	Hollow washer	2
2	Spanner nut	1
3	O-ring	15

TOLERANCES UNLESS OTHERWISE SPECIFIED			
FRACTIONS	±1/32	METRIC	
2 PLACE DECIMAL	±0.015	0.0 MM	±0.4MM
3 PLACE DECIMAL	±0.005	0.00MM	±0.1MM
ANGULARITY	±0.5°		
RUNDUT	±0.003 T.I.R.		

GPD Global	
NAME: Micro-Dot No Drip Kit	
USED ON:	
MATERIAL:	
HEAT TREAT: -	
FINISH:	
DRAWN BY: MK	PART NUMBER
CHECKED BY:	DO NOT SCALE DRAWING
DATE: 01/18/12	SCALE: N/A
22141047	REV A

Pump Luer (062-105) Support Kit - 22141056

Item	Description	Part No.	Qty
1	Teflon/Dielectric Grease	10/4150	1
2	Teflon Oil	10/3432	1
3	Cleaning Brushes	10/4155	2
4	Tubes with Luer Adapters	22110064	30
5	Pipe Cleaners	10/3900	1 pkg
6	Cotton Swab, Sharp Point	10/4878	1 pkg
7	Cotton Swab, Round Point	10/4879	1 pkg
8	Cotton Swabs	10/3473	1 pkg
9	Syringe & Plunger, 10 cc	10/4231	1
10	Allen Wrench Kit	10/3452	1
11	Spanner Wrench	22142029	1
12	5.5 mm Wrench	10/3356	1
13	Bellows Coupler	D1528	1
14	Taper Tips Needle Kit	10/4783	1
15	Syringe Nose Support, Small	22203656	1

Revision Notes			
A	12/20/10	Original issue.	
B	01/03/11	Major content changes; replace image.	
C	02/17/11	Add quantity to all parts, add 10/4878 and 10/4879.	
D	11/10/11	Present image of individual items including those not previously shown.	
E	02/04/14	Change quantity for 10/4878, 10/4879.	
F	09/29/15	10/4878 & 10/4879 revert to 11/10/2011 quantities.	
G	06/13/16	Add D1528 & 10/4783. Change 10/3451 to 22142029. Change 22110064 quantity. Change kit name.	
H	10/16/17	Add 22203656.	

TOLERANCES UNLESS OTHERWISE SPECIFIED				NAME: Pump Luer (062-105) Support Kit			
FRACTIONS ±1/32		METRIC		USED IN:		MATERIAL:	
2 PLACE DECIMAL ±0.015		0.0 MM		±0.4MM		HEAT TREAT: —	
3 PLACE DECIMAL ±0.005		0.00MM		±0.1MM		FINISH:	
ANGULARITY ±0.5°		RUNDOUT ±0.003 T.I.R.		DWG SIZE:		PART NUMBER	
DRAWN BY: MK				DO NOT SCALE DRAWING			
CHECKED BY:				DATE: 09/29/2015			
SCALE: N/A				22141056			
							REV
							H

HyFlo Pump Support Kit - 22142002

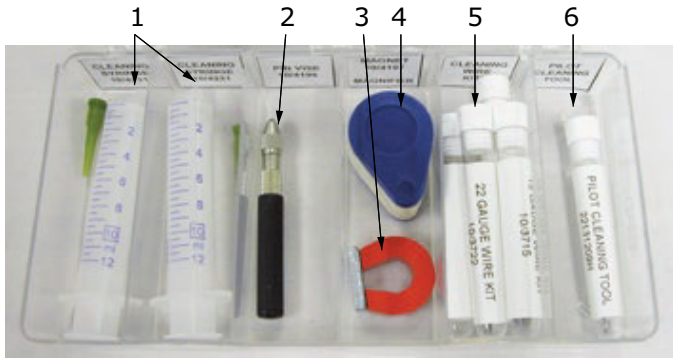

ITEM	DESCRIPTION	PART NO.
1	Cleaning Syringe & Plunger (10 cc)	10/4231
2	Pin Vise	10/4196
3	Magnet	10/4197
4	Multi-Lens Magnifier	2725-0029
5	Cleaning Wire Kits	*varies with configuration
6	Pilot Cleaning Tool	*varies with configuration
7	Spanner Wrench	22142029
8	Slotted Spanner Nut, Washers, O-rings	*varies with configuration
9	Cleaning Brushes 1/4" dia.	10/4775
10	Reservoir Tube	22110463
11	Pipe Cleaners	10/3900
12	Teflon/Dielectric Grease	10/4767
13	Teflon Oil	10/3432
14	Cotton Swabs	10/3473
15	Needles, Encapsulation Style	*varies with configuration
16	HyFlo Pump User Guide (not shown)	22293127M

* Optional support kit items are not applicable to all configurations.

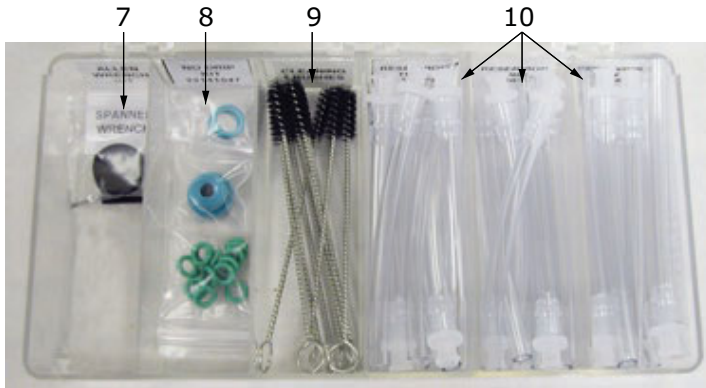

Revisions

- A Original issue.
- B 22110463 was 22110508.

TOLERANCES UNLESS OTHERWISE SPECIFIED				GPD Global Precision Dispensing Systems	
FRACTIONS	±1/32	METRIC		NAME: HyFlo Pump Support Kit	
6 PLACE DECIMAL	±0.015	0.0 MM	±0.4MM	USED ON:	
3 PLACE DECIMAL	±0.005	0.00MM	±0.1MM	MATERIAL:	
ANGULARITY	±0.5°			HEAT TREAT: -	
RUNDUT	±0.003 T.I.R.			FINISH:	
DRAWN BY: MK			PART NUMBER		REV
CHECKED BY:			22142002		B
DATE: 10/31/12			SCALE: N/A		

NCM5000 Pump Cleaning Kit - 22142051

Revision Notes		
A	05/05/2015	Original issue.
B	06/09/2015	Add content for kits 22142049, 22142050, & 22142052
C	09/29/2015	Add quantity in place of X indicator.
D	01/29/2021	Add *1" M2007 to 200 um PN 22142052 contents



*Each size of drill bit is provided in a separate tube.

Item	Description	Part No.	PN 22142049	PN 22142050	PN 22142051	PN 22142052
			75 µm	100 µm	125 µm	200 µm
1	Brush, Nylon, 3/64 dia	2650-0099	16	16	16	16
2	Pin Vise	10/4196	1	1	1	1
3	Cleaning Wires, 0.002" dia	2650-0269	1			
	Cleaning Wires, 0.003" dia	2650-0270		1		
	Cleaning Wires, 32 gauge	2650-0217			1	
4	Cleaning Wires, 0.007" dia	2650-0271				1
	Drill Bit, 1.32 mm dia	M2007	1	1	1	1
	Drill Bit, 1.030 mm dia	M2008	1	1	1	1
	Drill Bit, 0.200 mm dia	M2009	2			
	Drill Bit, 0.275 mm dia	M2010		2		
	Drill Bit, 0.345 mm dia	M2011			2	
	Drill Bit, 0.480 mm dia	M2012				2

TOLERANCES UNLESS OTHERWISE SPECIFIED				GPD Global® Precision Dispensing Systems	
NAME: NCM5000 Pump Cleaning Kits				22142049, 22142050, 22142051, 22142052	
FRACTIONS	#1/32	METRIC	0.0 MM	±0.4MM	MATERIAL:
2 PLACE DECIMAL	±0.015	0.0 MM	0.00MM	±0.1MM	HEAT TREAT: -
3 PLACE DECIMAL	±0.005				FINISH:
ANGULARITY	±0.5°				
RUNDUT	±0.003 T.I.R.				
DRAWN BY: MK				PART NUMBER	
CHECKED BY:				22142051	
DATE: 09/29/2015				REV: D	
DO NOT SCALE DRAWING				SCALE: N/A	

Precision Auger Pump Support Kit (186) - 22142053

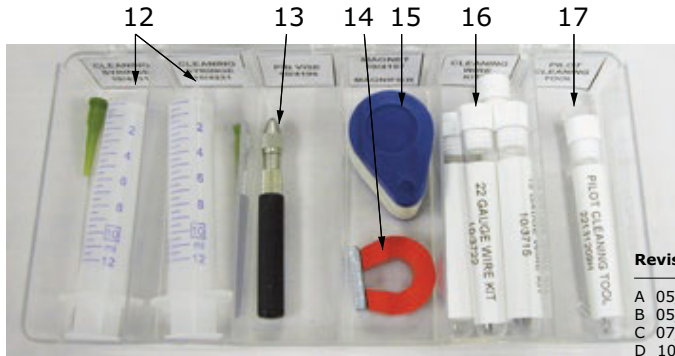
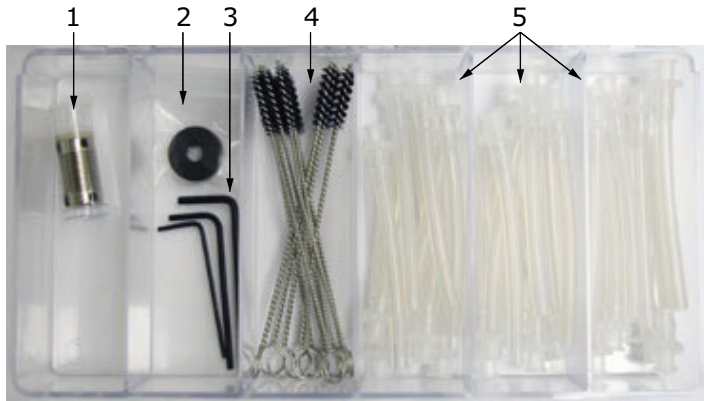

Pump Support

Needle Support

ITEM	DESCRIPTION	PART NO.
1	Auger Coupler 156 Hex	D1528
2	Spanner Wrench	22142029
3	Allen Wrench Kit	10/3452
4	Cleaning Brushes 1/4" dia.	10/4775
5	Feed Tube	22110463
6	Pathway Cleaners	10/3900
7	Teflon/Dielectric Grease	10/4767
8	Teflon Oil	10/3432
9	Cotton Swabs	10/3473
10	Needles	*Varies with configuration
11	Syringe Nose Support - large	22503016

12	Cleaning Syringe & Plunger (10 cc)	10/4231
13	Pin Vise	10/4196
14	Magnet	10/4197
15	Multi-Lens Magnifier	2725-0029
16	Cleaning Wire Kits	*Varies with configuration. Sizes listed below.
17	Pilot Cleaning Tool	22131209H

CLEANING WIRE KITS
 Each kit/set includes 8 tapered-tip wires and 3 scoop-end drill bits for a single gauge.
 18 gauge = 10/4311
 20 gauge = 10/3720
 21 gauge = 10/3721
 22 gauge = 10/3722
 23 gauge = 10/3723
 25 gauge = 10/3725
 27 gauge = 10/3727
 28 gauge = 10/3728
 30 gauge = 10/3730
 31 gauge = 10/3731
 32 gauge = 10/3732

* Optional support kit items are not applicable to all configurations.

NS = not shown

Revisions

- A 05/06/15 Original issue.
- B 05/18/15 Add 22503016.
- C 07/15/15 Add cleaning wire kit details.
- D 10/13/15 22110463 was 22110063.
- E 01/14/19 Change wire qty 4 to 8.

TOLERANCES UNLESS OTHERWISE SPECIFIED				GPD Global Precision Dispensing Systems	
FRACTIONS	±1/32	METRIC		NAME:	Precision Auger Pump Support Kit
2 PLACE DECIMAL	±0.015	0.0 MM	±0.4MM	USED ON:	Cartridge diameter 186
3 PLACE DECIMAL	±0.005	0.00MM	±0.1MM	MATERIAL:	
ANGULARITY	±0.5°			HEAT TREAT:	—
RUNDUT	±0.003 T.I.R.			FINISH:	
				DWG SIZE	
DRAWN BY: MK		DO NOT SCALE DRAWING		PART NUMBER	REV
CHECKED BY:		DATE: 01/14/19		22142053	E
		SCALE: N/A			

Precision Auger Pump Support Kit (105 / 062) - 22142054

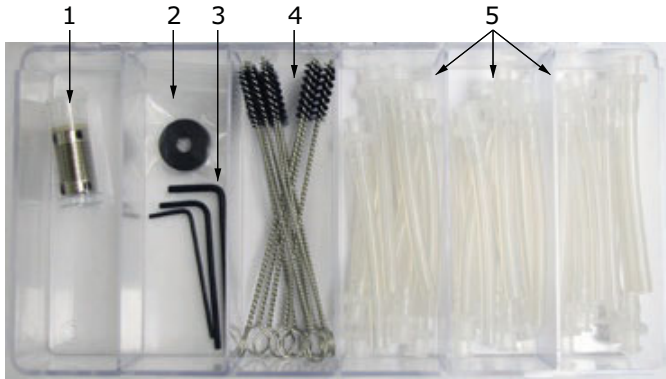

Pump Support

ITEM	DESCRIPTION	PART NO.
1	Auger Coupler 156 Hex	D1528
2	Spanner Wrench	22142029
3	Allen Wrench Kit	10/3452
4	Cleaning Brushes 1/4" dia.	10/4775
NS	Cleaning Brush 1/16" dia.	10/4899
5	Feed Tube	22110064
6	Pathway Cleaners	10/3900
7	Teflon/Dielectric Grease	10/4767
8	Teflon Oil	10/3432
9	Cotton Swabs	10/3473
10	Needles	*Varies with configuration
11	Syringe Nose Support - small	22203656
NS	Gauge Pin .062	2725-0076
NS	Gauge Pin .105	2650-0180



Needle Support

12	Cleaning Syringe & Plunger (10 cc)	10/4231
13	Pin Vise	10/4196
14	Magnet	10/4197
15	Multi-Lens Magnifier	2725-0029
16	Cleaning Wire Kits	*Varies with configuration. Sizes listed below.
17	Pilot Cleaning Tool	22131209H

CLEANING WIRE KITS
 Each kit/set includes 8 tapered-tip wires and 3 scoop-end drill bits for a single gauge.

- 18 gauge = 10/4311
- 20 gauge = 10/3720
- 21 gauge = 10/3721
- 22 gauge = 10/3722
- 23 gauge = 10/3723
- 25 gauge = 10/3725
- 27 gauge = 10/3727
- 28 gauge = 10/3728
- 30 gauge = 10/3730
- 31 gauge = 10/3731
- 32 gauge = 10/3732

* Optional support kit items are not applicable to all configurations.

NS = not shown

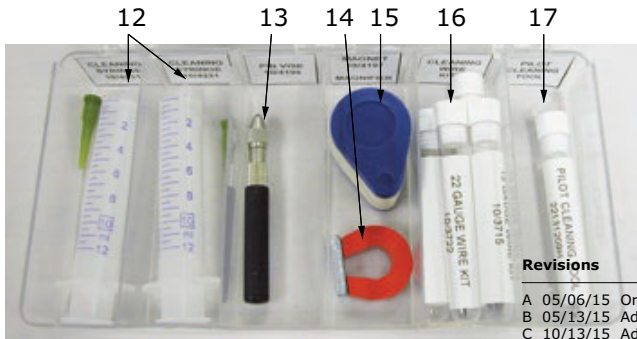

Revisions

- A 05/06/15 Original issue.
- B 05/13/15 Add 22503016.
- C 10/13/15 Add cleaning wire kit details.
- D 09/05/18 Add 2725-0076 & 10/4899.
- E 01/14/19 Add 2650-0180, change wire qty 4 to 8.



TOLERANCES UNLESS OTHERWISE SPECIFIED			NAME: Precision Auger Pump Support Kit	
FRACTIONS	±1/32	METRIC	USED ON:	Cartridge diameter 105 / 062
2 PLACE DECIMAL	±0.015	0.0 MM	MATERIAL:	
3 PLACE DECIMAL	±0.005	0.00MM	HEAT TREAT:	-
ANGULARITY	±0.5°		FINISH:	
RUNDOUT	±0.003 T.I.R.			
DRAWN BY: MK			PART NUMBER	
CHECKED BY:			22142054	
DATE: 01/14/2019			REV: E	
SCALE: N/A				

Pump Luer (186) Support Kit - 22142071

Revision Notes		
A	06/27/16	Original issue.
B	10/16/17	Add 22503016.



Item	Description	Part No.	Qty
1	Teflon/Dielectric Grease	10/4150	1
2	Teflon Oil	10/3432	1
3	Cleaning Brushes	10/4155	2
4	Brushes with Luer Adapters	22110463	30
5	Pipe Cleaners	10/3900	1 pkg
6	Cotton Swab, Sharp Point	10/4878	1 pkg
7	Cotton Swab, Round Point	10/4879	1 pkg
8	Cotton Swabs	10/3473	1 pkg
9	Syringe & Plunger, 10 cc	10/4231	1
10	Allen Wrench Kit	10/3452	1
11	Spanner Wrench	22142029	1
12	5.5 mm Wrench	10/3356	1
13	Bellows Coupler	D1528	1
14	Taper Tips Needle Kit	10/4783	1
15	Syringe Nose Support, Large	22503016	1

TOLERANCES UNLESS OTHERWISE SPECIFIED				GPD Global® Precision Dispensing Systems	
FRACTIONS	1/32	METRIC	0.0 MM	NAME: Pump Luer (186) Support Kit	
2 PLACE DECIMAL	±0.015	0.0 MM	±0.4MM	USED ON:	
3 PLACE DECIMAL	±0.005	0.00MM	±0.1MM	MATERIAL:	
ANGULARITY	±0.5°			HEAT TREAT: -	
RUNDOUT	±0.003 T.I.R.			FINISH:	
DRAWN BY: MK			PART NUMBER		
CHECKED BY:			REV		
DATE: 06/27/2016			22142071		
SCALE: N/A			B		

Pump Luer Legacy Support Kit - 22144014

Revision Notes

A 08/21/2017 Original issue.



Item	Description	Part No.	Qty
1	Teflon/Dielectric Grease	10/4150	1
2	Teflon Oil	10/3432	1
3	Cleaning Brushes	10/4155	2
4	Tubes with Luer Adapters	22110064	30
5	Pipe Cleaners	10/3900	1 pkg
6	Cotton Swab, Sharp Point	10/4878	1 pkg
7	Cotton Swab, Round Point	10/4879	1 pkg
8	Cotton Swabs	10/3473	1 pkg
9	Syringe & Plunger, 10 cc	10/4231	1
10	Allen Wrench Kit	10/3452	1
11	Spanner Wrench	10/3451	1
12	5.5 mm Wrench	10/3356	1
13	Coupling Assembly	10/3660	1
14	Taper Tips Needle Kit	10/4783	1

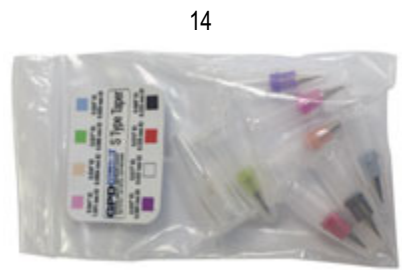

<p>TOLERANCES UNLESS OTHERWISE SPECIFIED</p> <table border="0"> <tr> <td>FRACTIONS</td> <td>±1/32</td> <td>METRIC</td> <td></td> </tr> <tr> <td>2 PLACE DECIMAL</td> <td>±0.015</td> <td>0.0 MM</td> <td>±0.4MM</td> </tr> <tr> <td>3 PLACE DECIMAL</td> <td>±0.005</td> <td>0.00MM</td> <td>±0.1MM</td> </tr> <tr> <td>ANGULARITY</td> <td>±0.5°</td> <td></td> <td></td> </tr> <tr> <td>RUNDOUT</td> <td>±0.003 T.I.R.</td> <td></td> <td></td> </tr> </table>				FRACTIONS	±1/32	METRIC		2 PLACE DECIMAL	±0.015	0.0 MM	±0.4MM	3 PLACE DECIMAL	±0.005	0.00MM	±0.1MM	ANGULARITY	±0.5°			RUNDOUT	±0.003 T.I.R.			<p>GPD Global Precision Dispensing Systems</p>	
FRACTIONS	±1/32	METRIC																							
2 PLACE DECIMAL	±0.015	0.0 MM	±0.4MM																						
3 PLACE DECIMAL	±0.005	0.00MM	±0.1MM																						
ANGULARITY	±0.5°																								
RUNDOUT	±0.003 T.I.R.																								
NAME: Pump Luer Legacy Support Kit																									
USED ON:																									
MATERIAL:																									
HEAT TREAT: -																									
DRAWN BY: MK		FINISH:																							
CHECKED BY:		PART NUMBER																							
DATE: 08/21/2017		22144014																							
SCALE: N/A		REV: A																							

Needle Cleaner, Grip - 22150521

Revision Notes

- A Original issue.
- B Update quantity for 22150522.

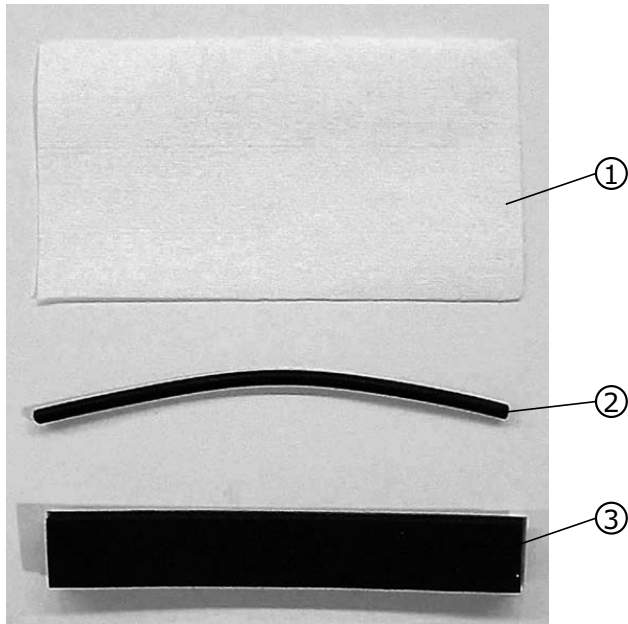

Item	Description	Part No.	Qty
1	Needle patch	22150522	1 package
2	Bead cord	22150524	4
3	Soft jaw	22150523	4

GPD Global

TOLERANCES UNLESS OTHERWISE SPECIFIED				NAME: Needle Cleaner Kit (Grip Type)	
FRACTIONS	±1/32	METRIC		USED ON	
2 PLACE DECIMAL	±0.015	0.0 MM	±0.4MM	MATERIAL	
3 PLACE DECIMAL	±0.005	0.00MM	±0.1MM	HEAT TREAT	--
ANGULARITY	±0.5°			FINISH	
RUNDOUT	±0.003 T.I.R.				
		DWG SIZE		PART NUMBER	REV
DRAWN BY: MK				22150521	B
CHECKED BY:	DO NOT SCALE DRAWING	DATE: 01/15/10	SCALE: N/A		

Conveyor, DS Series - 22164101A

Revision Notes

A Original issue.

B Replace 2475-0021 with 3700-0053

Item	Description	Part No.	Qty
1	Cable/Connector	2475-0023	1
2	Photo Electric Sensor	3700-0053	1
3	Mounted Ball Bearing	B0304	2
4	Photo Electric Amplifier	3700-0052	1
5	Cam Follower	10/2135	2
6	Air Cylinder	10/2132	1
7	One-Touch Plug	10/1772	10
8	Belt End Rail Pulley	22160151	1
9	Belt Idler Pulley	22160152	1
10	Connector	10/0905	2
11	Speed Control	2200-0115	1
12	#25 Chain Masterlink	RCML025	1
13	Solenoid Valve, 5 port	10/1622	1
14	Conveyor Belt	10/2281	1
15	Solenoid Valve, 3 port	10/1747	1

NOTE: Items are not shown to scale

TOLERANCES UNLESS OTHERWISE SPECIFIED		GPD Global	
FRACTIONS	±1/32	METRIC	USED IN:
2 PLACE DECIMAL	±0.015	0.0 MM	MATERIAL:
3 PLACE DECIMAL	±0.005	0.00MM	HEAT TREAT: -
ANGULARITY	±0.5°		FINISH:
RUNDUT	±0.003 T.I.R.	DWG. SIZE:	PART NUMBER
DRAWN BY: MK		22164101A	
CHECKED BY:	DO NOT SCALE DRAWING	REV	
DATE: 06/10/09	SCALE: N/A	B	

Calibration Station Parts List - 22200618



Calibration Station Parts List

PN 22200618
as of 11/25/2015

Consumable & Suggested Parts					Standard Calibration Station Styles					
Item	Part No.	Description	Consumable	Suggested	Ceramic/Backlit Module	Paper/Backlit Module	Base Module	Dual Pump Ceramic/Backlit 2 CTC	Dual Pump Ceramic/Backlit 3.5 CTC	Impression Pad
					22295066	22295067	22295070	22295093	22295085	22295068
1	22205215	Calibration Chip (.005, .008, .011, .040)		X			X			
2	22205367	Calibration Chip, Black Glass		X						
3	22205168	Ceramic Plate		X	X	X		X	X	
4	22205286	Impression Pad	X							X
5	10/1940	Purge cup, plastic	X				X	X	X	
6	10/4890	Purge cup, plastic, center cone	X							
7	3000-0102	Paper roll	X							
8	10/4015	Paper roll, thermal	X			X				

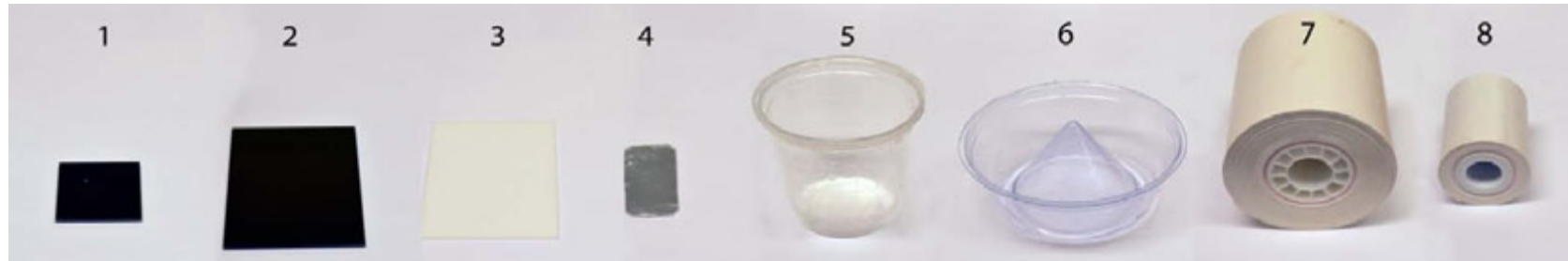

Scale Weight Kit - 22213013

Revision Notes
A 07/07/22 Original issue



Item	Description	Part No.	Qty
1	Weigh Pan, 10G, w/Certificate	2925-0006	1
2	Weigh Pan, 20G, w/Certificate	2925-0005	1
3	Weighing Pan, 15 MM	2200-0384	1
4	Weighing Pan Adapter, 14 MM	2200-0386	1
5	Weight Handling Tweezers	2925-0015	1
6	Scale Weight Kit Procedure	22213013M	1
7	Glove with Rubber Tips	2925-0008	1 pair



TOLERANCES UNLESS OTHERWISE SPECIFIED				NAME: Scale Weight Kit	
FRACTIONS	±1/32	METRIC		USED ON:	
2 PLACE DECIMAL	±0.015	0.0 MM	±0.4MM	MATERIAL:	
3 PLACE DECIMAL	±0.005	0.00MM	±0.1MM	HEAT TREAT:	-
ANGULARITY	±0.5°			FINISH:	
RUNOUT	±0.003 T.I.R.			PART NUMBER	22213013
DRAWN BY: MK				SCALE	REV
CHECKED BY:				DO NOT SCALE DRAWING	A
DATE: 07/07/22				SCALE: N/A	

MAX Series, Level 1 (Legacy) - 22290005A

Revision Notes

- A Original issue.
- B Change 10/1940 quantity from 1 to 5.
- C Replace Lubricant 10/2204 with Grease 10/3207.
- D Change Coupler 10/3477 to 10/4777, and 22150522 qty from 20 to 1 pkg.

Item	Description	Part No.	Qty
1	Hood Fan	2600-0022	1
2	Thermal Paper	3000-0102	1
3	Fuse	4300-0046	5
4	Plug	10/1772	2
5	Connector	10/1690	4
6	Solenoid Valve	10/1622	2
7	Fuse	4300-0072	10
8	Fuse	4300-0034	9
9	Opto Switch	10/0221	1
10	Opto Switch Sensor	3700-0101	1
11	Grease, AS2 (0.08 g)	10/3207	1
12	Plastic Cup	10/1940	5
13	Fuse	4300-0045	10
14	Fuse	4300-0026	4
15	Cam Follower	10/2135	2
16	Relay	4500-0013	1
17	Touch Probe	22203215	1
18	Coupler	10/4777	1
19	Opto Switch, 90 deg	22150025	2
20	Needle Cleaner Wipe	22150522	1 pkg
21	Needle Cleaner Cord	22150524	4
22	Needle Cleaner Jaws	22150523	4

TOLERANCES UNLESS OTHERWISE SPECIFIED		GPD Global	
FRACTIONS	±1/32	METRIC	NAME: MicroMax Spare Parts Kit - Level 1
2 PLACE DECIMAL	±0.015	0.0 MM	USED ON:
3 PLACE DECIMAL	±0.005	0.00MM	MATERIAL:
ANGULARITY	±0.5°		HEAT TREAT: -
RUNDUT	±0.003 T.I.R.		FINISH:
DRAWN BY: MK		DWG SIZE	PART NUMBER
CHECKED BY:		DO NOT SCALE DRAWING	22290005A
DATE: 02/17/11	SCALE: N/A		REV: D

MAX Series, Level 2 (Legacy) - 22290005B

Revision Notes
 A Original issue.

Item	Description	Part No.	Qty
1	Touch Probe	22203215	1
2	Fuse	4300-0046	5
3	Connector	10/1690	4
4	Solenoid Valve	10/1622	2
5	Fuse	4300-0072	10
6	Fuse	4300-0045	10
7	Fuse	4300-0026	4
8	Opto Switch	10/0221	1
9	Grease, AS2 (0.08 g)	10/3207	1
10	Coupler	D1531	1
19	Opto Switch, 90 deg	3700-0025	2

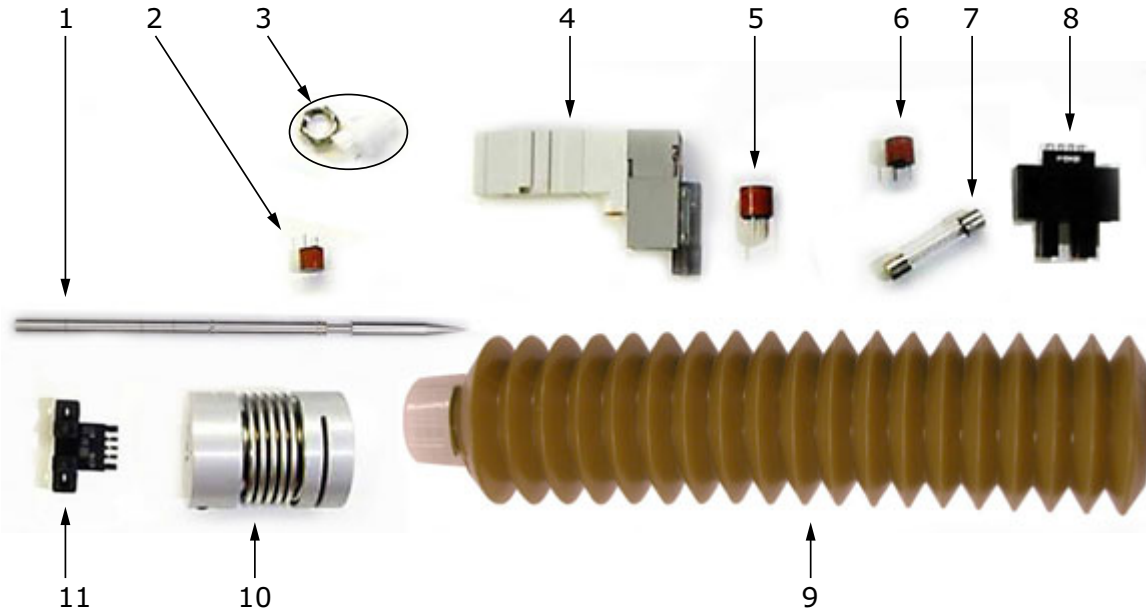

TOLERANCES UNLESS OTHERWISE SPECIFIED FRACTIONS ±1/32 METRIC 2 PLACE DECIMAL ±0.015 0.0 MM ±0.4MM 3 PLACE DECIMAL ±0.005 0.00MM ±0.1MM ANGULARITY ±0.5° RUNDUT ±0.003 T.I.R.		GPD Global Precision Dispensing Systems	
		NAME: MicroMax Spare Parts Kit - Level 2	
DRAWN BY: MK		USED ON:	
CHECKED BY:		MATERIAL:	
DATE: 12/22/15		HEAT TREAT: -	
DO NOT SCALE DRAWING		FINISH:	
SCALE: N/A		PART NUMBER	
		22290005B	
		REV	
		A	

MAX Series Spare Parts Kit (Legacy) - 22290005

Revision Notes

A 11/13/02 Original issue.
 B 03/23/04 Removed stack light 2450-0076.
 C 02/08/05 Add needle cleaner and calibration station parts plus fan. Remove various parts.
 D 06/05/06 Add probe 22120999 and switch 3700-0029. Change 10/1940 quantity from 1 to 5.
 E 10/21/11 Change Coupler 10/3477 to 10/4777, and 22150522 qty from 20 to 1 pkg.
 F 02/04/14 10/4777 replaces 10/3477; remove 3700-0029; change 22150522 qty unit.

Item Description	Part No.	Qty
1 Relay	4500-0013	1
2 Coupler	10/4777	1
3 Opto Switch	3700-0025	2
4 Needle Cleaner Wipe	22150522	1 pkg
5 Needle Cleaner Cord	22150524	4
6 Needle Cleaner Jaws	22150523	4
7 Hood Fan	2600-0022	1
8 Thermal Paper	3000-0102	1
9 Fuse	4300-0046	5
10 Plug	10/1772	2
11 Connector	10/1690	4
12 Solenoid valve	10/1622	2
13 Fuse	4300-0072	10
14 Fuse	4300-0034	9
15 Opto switch	10/0221	1
16 Lubricant	10/2204	1
17 Plastic Cup	10/1940	5
18 Fuse	4300-0045	10
19 Fuse	4300-0026	4
20 Touch Probe, hardened	22120999	1
21 Cam Follower	10/2135	2

TOLERANCES UNLESS OTHERWISE SPECIFIED		NAME: MicroMax Spare Parts Kit	
FRACTIONS	±1/32	METRIC	USED ON:
2 PLACE DECIMAL	±0.015	0.0 MM	MATERIAL:
3 PLACE DECIMAL	±0.005	0.00MM	HEAT TREAT: --
ANGULARITY	±0.5°		FINISH:
RUNDUT	±0.003 T.I.R.		
DRAWN BY: MK	DWG. SIZE:	PART NUMBER	REV
CHECKED BY:	DO NOT SCALE DRAWING	22290005	F
DATE: 11/13/02	SCALE: N/A		

TOLERANCES UNLESS OTHERWISE SPECIFIED		NAME: MicroMax Spare Parts Kit	
FRACTIONS	±1/32	METRIC	USED ON:
2 PLACE DECIMAL	±0.015	0.0 MM	MATERIAL:
3 PLACE DECIMAL	±0.005	0.00MM	HEAT TREAT: --
ANGULARITY	±0.5°		FINISH:
RUNDUT	±0.003 T.I.R.		
DRAWN BY: MK	DWG. SIZE:	PART NUMBER	REV
CHECKED BY:	DO NOT SCALE DRAWING	22290005	F
DATE: 11/13/02	SCALE: N/A		

Conveyor, MAX Series - 22290010

7/7/22

Kits & Parts for Dispensers & Related Equipment

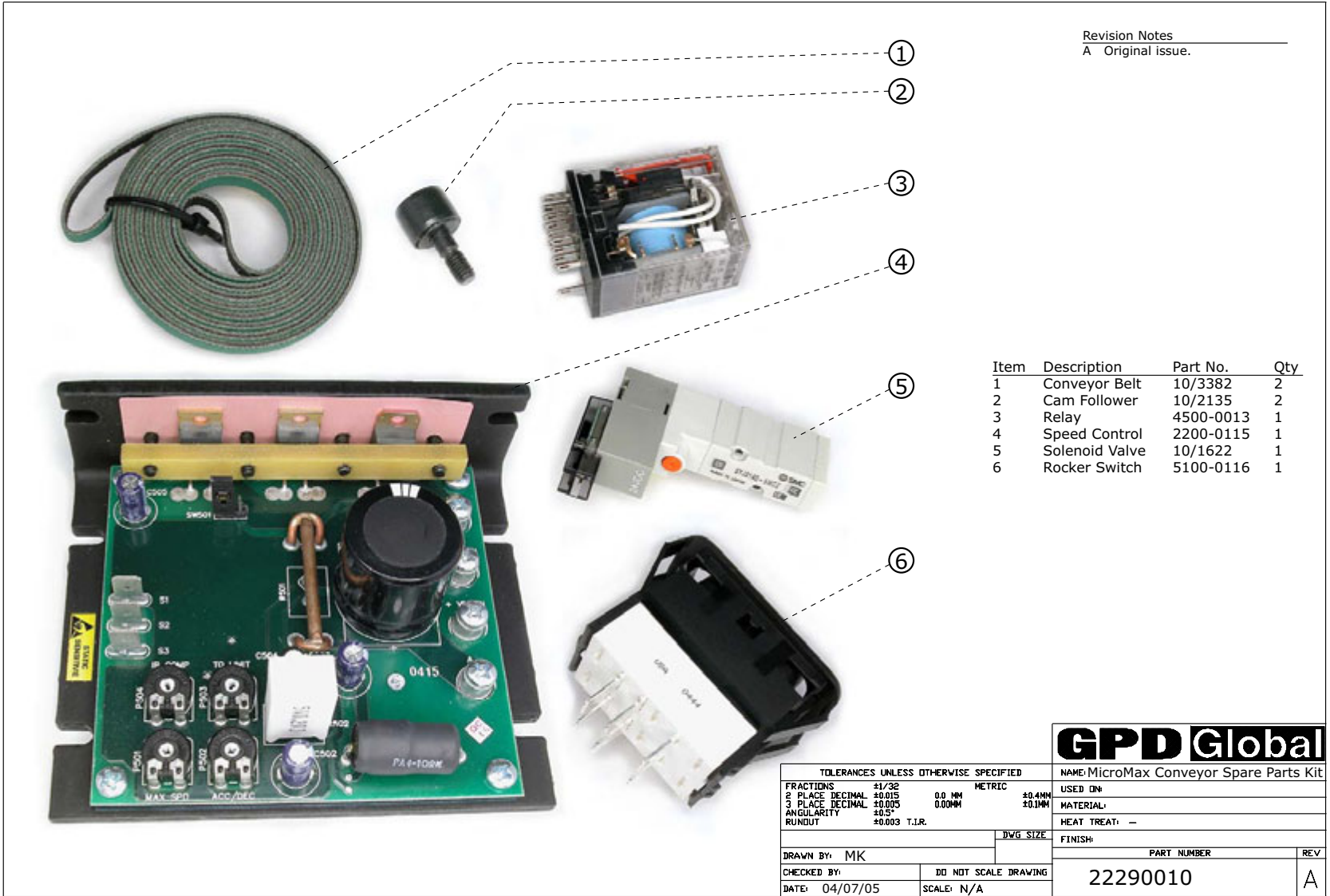

Revision Notes
A - Original issue.

Item	Description	Part No.	Qty
1	Conveyor Belt	10/3382	2
2	Cam Follower	10/2135	2
3	Relay	4500-0013	1
4	Speed Control	2200-0115	1
5	Solenoid Valve	10/1622	1
6	Rocker Switch	5100-0116	1

GPD Global

TOLERANCES UNLESS OTHERWISE SPECIFIED		NAME: MicroMax Conveyor Spare Parts Kit	
FRACTIONS	#1/32	METRIC	USED ON:
2 PLACE DECIMAL	±0.015	0.0 MM	±0.4MM
3 PLACE DECIMAL	±0.005	0.00MM	±0.1MM
ANGULARITY	±0.5°		MATERIAL:
RUNDUNT	±0.003 T.I.R.		HEAT TREAT: -
		DWG SIZE:	FINISH:
DRAWN BY: MK			PART NUMBER
CHECKED BY:	DD NOT SCALE DRAWING		22290010
DATE: 04/07/05	SCALE: N/A		REV A

Needle Cleaner, Grip Multiwipe - 22290034

Revision Notes
 A Original issue.
 B 22290034 replaces 22151089.



Detail: Top and Side views



Item	Description	Qty	P/N
1	Multi-style Foam Needle Wipes	1 pkg	22290034

GPD Global

TOLERANCES UNLESS OTHERWISE SPECIFIED				NAME: Needle Cleaner Spare Parts Kit	
FRACTIONS	1/32	METRIC		USED ON:	Grip / Multi Wipe
2 PLACE DECIMAL	±0.015	0.0 MM	±0.4MM	MATERIAL:	
3 PLACE DECIMAL	±0.005	0.00MM	±0.1MM	HEAT TREAT:	—
ANGULARITY	±0.5°			FINISH:	
RUNDOUT	±0.003 T.I.R.				
		DWG SIZE		PART NUMBER	REV
DRAWN BY:				22290034	B
CHECKED BY:	MK	DO NOT SCALE DRAWING			
DATE:	08/13/12	SCALE:	N/A		

NCM5000 Pump Maintenance Tool Kit - 22290042

Revision Notes

A 11/13/2014 Original issue.



①

②

③

④

⑤

Item	Description	Qty
1	Gap Setting Tool	1
2	Solenoid Torque Tool	1
3	Loctite	1
4	Hex Driver, 5/64	1
5	Hex Wrench, 0.050	1



TOLERANCES UNLESS OTHERWISE SPECIFIED		NAME: NCM5000 Pump Maintenance Tool Kit	
FRACTIONS	±1/32	METRIC	USED ON:
2 PLACE DECIMAL	±0.015	0.0 MM	±0.4MM
3 PLACE DECIMAL	±0.005	0.00MM	±0.1MM
ANGULARITY	±0.5°		MATERIAL:
RUNDOUT	±0.003 T.I.R.		HEAT TREAT: -
	DWG. SIZE:	FINISH:	
DRAWN BY: MK		PART NUMBER	REV
CHECKED BY:	DO NOT SCALE DRAWING	22290042	A
DATE: 11/13/14	SCALE: N/A		

NCM5000 Pump Maintenance Kit (Legacy) - 22290043



Revision Notes

- A 11/12/2014 Original issue.
- B 09/01/2015 Update 2650-0244 image. List 2220-0123 for item 3.
- C 10/13/2015 Add 2650-0303.
- D 07/27/2016 Add 2650-0323 to item 1 and 2650-0322 to item 4.
Change 2220-0123 to 2650-0321.

Item	Description	Part No.	Qty
1	Solenoid	2650-0323	1
2	Air Cylinder	2650-0244	1
3	Compression Spring	2650-0321	1
4	Exhaust Muffler	2650-0322	1
5	Heater Block Bushing	2650-0303	1



TOLERANCES UNLESS OTHERWISE SPECIFIED		NAME: NCM5000 Pump Maintenance Kit	
FRACTIONS ±1/32	METRIC	USED ON: Legacy (no cross seal pumps)	MATERIAL:
2 PLACE DECIMAL ±0.015	0.0 MM ±0.4MM	HEAT TREAT: -	
3 PLACE DECIMAL ±0.005	0.00MM ±0.1MM	FINISH:	
ANGULARITY ±0.5°		PART NUMBER	
RUNDUT ±0.003 T.I.R.		22290043	
DRAWN BY: MK	DO NOT SCALE DRAWING	REV	
CHECKED BY:	SCALE: N/A	D	
DATE: 11/12/14			

PCD Micro Pump Support Kit - 22290172

Revisions

A 11/08/17 Original issue.



Item	Description	Part No.	Qty
1	Taper Tips Needle Kit	10/4783	1 pkg
2	Brush, Nylon, 5/32" dia	10/4155	2
3	Brush, Nylon, 1/4" dia	10/4775	2
4	Material Pathway Cleaners	10/3900	1 pkg
5	Cotton Swab, Round Point	10/4879	1 pkg
6	Cotton Swab, Sharp Point	10/4878	1 pkg
7	Absorbant Thread Cleaner	10/3473	1 pkg
8	Brush, Nylon, 3/8" dia	10/4909	2
9	Luer Lock 3-Way Stop Cock	2625-0020	1
10	Wrench, Hex-Key, 1.5 mm	M2024	1
11	Wrench, Open End, 11x9 mm	M2025	1
12	Wrench, Combination, 12 mm	M2026	1
13	Screw Driver, Slotted, Small	M2027	1

TOLERANCES UNLESS OTHERWISE SPECIFIED				GPDGlobal Precision Dispensing Systems	
FRACTIONS	±1/32	METRIC	0.0 MM	NAME: PCD Micro Pump Support Kit	
2 PLACE DECIMAL	±0.015	0.00MM	±0.4MM	USED ON:	
3 PLACE DECIMAL	±0.005	0.00MM	±0.1MM	MATERIAL:	
ANGULARITY	±0.5°			HEAT TREAT: -	
RUNDOUT	±0.003 T.I.R.			FINISH:	
DRAWN BY: MK			PART NUMBER		
CHECKED BY:			22290172		
DATE: 11/08/17			SCALE: N/A		
					REV A

MAX Series Spare Parts Kit - 22290174

Revision Notes
 A 02/17/20 Original issue.

Item Description	Part No.	Qty
1 Coupler	D1531	1
2 Opto Sensor (XY axis)	3700-0025	2
3 Opto Sensor (Z axis)	10/0221	1
4 Fuse, 1 Amp	4300-0112	2
5 Connector	10/1690	4
6 Solenoid Valve	10/1622	2
7 Ceramic Plate	22205168	2
8 Taper Lock Thumbscrew	22110565	2
9 Fuse, 6.3 Amp	4300-0046	5
10 Fuse, 2 Amp	4300-0045	10
11 Plastic Cup	10/1940	5
12 Touch Probe, hardened	22203215	1
13 Needle Cleaner Kit	22290034	1
14 Lubricant	10/3207	1

GPD Global Precision Dispensing Systems	
NAME: MAX Series Spare Parts Kit	
TOLERANCES UNLESS OTHERWISE SPECIFIED	USED ON:
FRACTIONS ±1/32	METRIC ±0.1MM
2 PLACE DECIMAL ±0.015	0.0 MM ±0.1MM
3 PLACE DECIMAL ±0.005	0.00MM ±0.1MM
ANGULARITY ±0.5°	HEAT TREAT: —
RUNDOUT ±0.003 T.I.R.	FINISH:
MK	DWG SIZE:
DRAWN BY:	PART NUMBER
CHECKED BY:	22290174
DATE: 02/17/20	REV
DO NOT SCALE DRAWING	A
SCALE: N/A	

NCM8350 Pump Cleaning Kit - 22293137



Revisions

A Original issue.

#	DESCRIPTION	PART NO.	QTY
1	Brush, Nylon, 1/16" dia	10/4899	10
2	Brush, Nylon, 3/32" dia	10/4900	10
3	Material Pathway Cleaners	10/3900	1 pkg
4	Cotton Swab, Sharp Point	10/4878	4 pkg
5	Cotton Swab, Round Point	10/4879	4 pkg
6	Absorbant Thread Cleaner	10/3473	4 pkg



TOLERANCES UNLESS OTHERWISE SPECIFIED		NAME: NCM8350 Expanded Pump Cleaning Kit	
FRACTIONS	±1/32	METRIC	USED ON:
2 PLACE DECIMAL	±0.015	0.0 MM	MATERIAL:
3 PLACE DECIMAL	±0.005	0.00MM	HEAT TREAT: -
ANGULARITY	±0.5°		FINISH:
RUNDOUT	±0.003 T.I.R.		
DRAWN BY: MK		DWG SIZE	PART NUMBER
CHECKED BY:		DO NOT SCALE DRAWING	REV
DATE: 12/17/12	SCALE: N/A	22293137	A

NCM5000 Pump Heater Repair Kit - 22293252

Revisions

A 09/23/15 Original issue.

Item	Description	Qty
1	Heater block with bushing	1
2	Cable ties, 4"	5
3	Heater block screws	2
4	Hose with connector	1



<p>TOLERANCES UNLESS OTHERWISE SPECIFIED</p> <p>FRACTIONS ±1/32 METRIC ±0.4MM 2 PLACE DECIMAL ±0.015 0.0 MM ±0.1MM 3 PLACE DECIMAL ±0.005 0.00MM ANGULARITY ±0.5° RUNDOUT ±0.003 T.I.R.</p>		<p>GPD Global Precision Dispensing Systems</p>	
		<p>NAME: NCM5000 Heater (Thick) Repair Kit</p>	
<p>USED ON:</p>		<p>MATERIAL:</p>	
<p>FINISH:</p>		<p>HEAT TREAT: -</p>	
<p>DRAWN BY: MK</p>		<p>DWG. SIZE:</p>	
<p>CHECKED BY:</p>		<p>DD NOT SCALE DRAWING</p>	
<p>DATE: 09/23/2015</p>		<p>SCALE: N/A</p>	
		<p>FINISH:</p>	
		<p>PART NUMBER</p>	
		<p>22293252</p>	
		<p>REV</p>	
		<p>A</p>	

Stamping Tool Indicator Alignment Kit - 22293266

7/7/22

Kits & Parts for Dispensers & Related Equipment

41



Revisions

A 10/26/15 Original issue.

Item	Description	Part No.	Qty
1	Alignment Cap	22203684	1
2	Indicator Interface Pin	22203685	1
3	Indicator Dovetail	M4004	1
4	Indicator Dovetail Attach	M4005	1



TOLERANCES UNLESS OTHERWISE SPECIFIED		NAME: Indicator Attach/Tool Alignment Kit	
FRACTIONS ±1/32	METRIC ±0.4MM	USED ON:	
2 PLACE DECIMAL ±0.015	0.0 MM ±0.1MM	MATERIAL:	
3 PLACE DECIMAL ±0.005	0.00MM	HEAT TREAT: —	
ANGULARITY ±0.5°		FINISH:	
RUNDOUT ±0.003 T.I.R.		PART NUMBER	
DRAWN BY: MK		22293266	
CHECKED BY:		DO NOT SCALE DRAWING	
DATE: 10/26/2015	SCALE: N/A	REV: A	

NCM5000 Pump Maintenance Kit (Cross Seal) - 22293343

Revision Notes
 A 08/19/2020 Original issue.



Item	Description	Part No.	Qty
1	Drive Solenoid	2650-0323	1
2	Main Cylinder (no washers)	2650-0325	1
3	Compression Spring	2650-0321	1
4	Exhaust Muffler	2650-0322	1
5	Heater Block Bearing	2650-0303	1
6	Lever	2650-0318	1
7	Shoulder Bolt	2650-0319	1
8	Heater Seal	2650-0315	1
9	Washer	2650-0316	1

GPD Global Precision Dispensing Systems			
TOLERANCES UNLESS OTHERWISE SPECIFIED		NAME: NCM5000 Pump Maintenance Kit	
FRACTIONS	±1/32	METRIC	USED ON: Cross Seal version of pump
2 PLACE DECIMAL	±0.015	0.0 MM	±0.4MM
3 PLACE DECIMAL	±0.005	0.00MM	±0.1MM
ANGULARITY	±0.5°		MATERIAL:
RUNDUT	±0.003 T.I.R.		HEAT TREAT: -
		DWG SIZE	FINISH
DRAWN BY: MK		PART NUMBER	
CHECKED BY:		22293343	
DATE: 08/19/2020		SCALE: N/A	REV: A

Gantry Lubrication Kit - 22294003

Revisions

- A 09/10/15 Original issue.
- B 12/21/15 Update part descriptions/coordinate with image.

Item	Description	Part No.	Qty
1	Grease Pump Needle Point, 90 deg	M2018	1
2	Grease Pump Flexible Nozzle	M2017	1
3	Grease Pump Bellow Cartridge	M2016	1
4*	Grease & MSDS sheet	10/3207	REF

*included with machine.



TOLERANCES UNLESS OTHERWISE SPECIFIED		GPD Global Precision Dispensing Systems	
FRACTIONS	±1/32	METRIC	±0.4MM
2 PLACE DECIMAL	±0.015	0.0 MM	±0.1MM
3 PLACE DECIMAL	±0.005	0.00MM	
ANGULARITY	±0.5°		
RUNDOUT	±0.003 T.I.R.		
DRAWN BY: MK		FINISH:	
CHECKED BY:		PART NUMBER	
DATE: 09/10/2015		22294003	
SCALE: N/A		REV: B	

Calibration Station Spare Parts - Ceramic - 22295043-0001

Revisions

A 06/01/22 Original issue.

Item	Description	Part No.	Qty
1	Ceramic Plate, White	22205168	1
2	Calibration Chip	22205215	1
3	Cup, Plastic, 1 oz	10/1940	10
4	Needle Cleaner Grip Multiwipe	22290034	1 kit



TOLERANCES UNLESS OTHERWISE SPECIFIED					
FRACTIONS	±1/32	METRIC		NAME: Calibration Spare Parts Kit - Ceramic	
2 PLACE DECIMAL	±0.015	0.0 MM	±0.4MM	USED ON:	
3 PLACE DECIMAL	±0.005	0.00MM	±0.1MM	MATERIAL:	
ANGULARITY	±0.5°			HEAT TREAT: --	
RUNOUT	±0.003 T.I.R.			FINISH:	
DRAWN BY: MK			PART NUMBER		REV
CHECKED BY:			22295043-0001		A
DATE: 06/01/2022			SCALE: N/A		

Needle Cleaner Wipe (Pad Type) Assembly Kit - 22295088

Revision Notes

A Original issue.

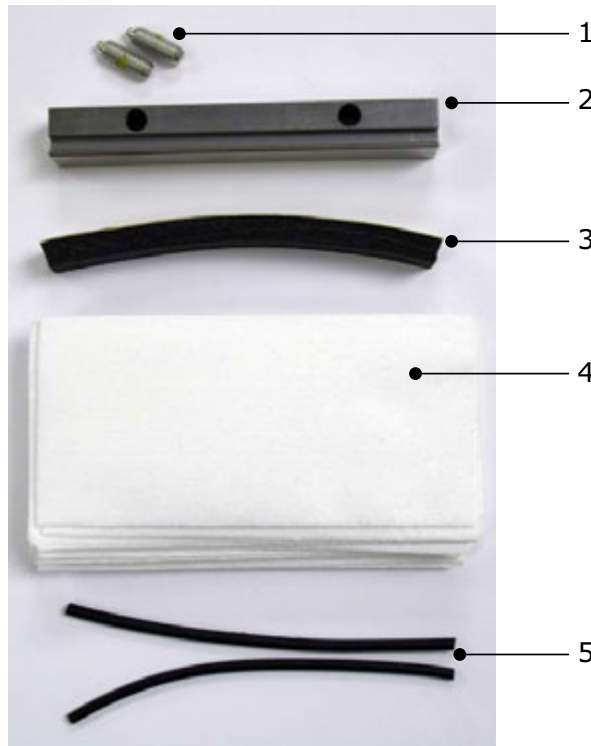

Item	Description	Part No.	Qty
1	Stubby Plunger	S5004	2
2	Wiper Bar, Grip TYPe	22150469	1
3	Jaw, Soft, Grip Type	22150523	1
4	Patch, Grip Type	22150522RM	1 bag
5	Bead Cord, Grip Type	22150524	2



TOLERANCES UNLESS OTHERWISE SPECIFIED		NAME: Needle Cleaner Wipe Assy Kit	
FRACTIONS	±1/32	METRIC	USED ON: (Pad Type)
2 PLACE DECIMAL	±0.015	0.0 MM	±0.4MM
3 PLACE DECIMAL	±0.005	0.00MM	±0.1MM
ANGULARITY	±0.5°		MATERIAL:
RUNDUT	±0.003 T.I.R.		HEAT TREAT: --
		DWG SIZE	FINISH:
DRAWN BY: MK			PART NUMBER
CHECKED BY:	DO NOT SCALE DRAWING		REV
DATE: 03/25/14	SCALE: N/A	22295088	A

ClearVU Vision Focus Tool - 22295104

Parts List			
ITEM	QTY	PART NUMBER	DESCRIPTION
1	1	22215000	FOCUS TOOL, CLEAR-VU
2	1	22215009	LEVEL/HEIGHT UNIT_FOCUS TOOL
3	1	22205359	ADAPTER PLT_FOCUS TL/LEGACY CAL STAT
4	5	LINE STOCK	CAP SCREW 4-40 X 1/4LG SST

TOLERANCES UNLESS OTHERWISE SPECIFIED			
	FRACTIONS	METRIC	
	± .132		
	XXX	± 0.015	0 MM ± 1.0 MM
	XXXX	± 0.005	0.0 MM ± 0.4 MM
	ANGULAR	± 0.5	0.00 MM ± 0.1 MM
	RUNOUT	± 0.003 T.I.R.	
FINISH	N/A		
HEAT TREATMENT	N/A		
DWG SIZE	B		

GPD Global		
DESCRIPTION		
KIT FOCUS TOOL CLEAR VU		
ASSEMBLY		
CLEARVU CAMERAS		
MATERIAL		
N/A		
DWG NO		
22295104		
DRAWN BY	6/14/2011	SHEET 1 OF 1
ALJ		

Needle Cleaner, Grip Synthetic - 22295111

Revision Notes

A Original issue.

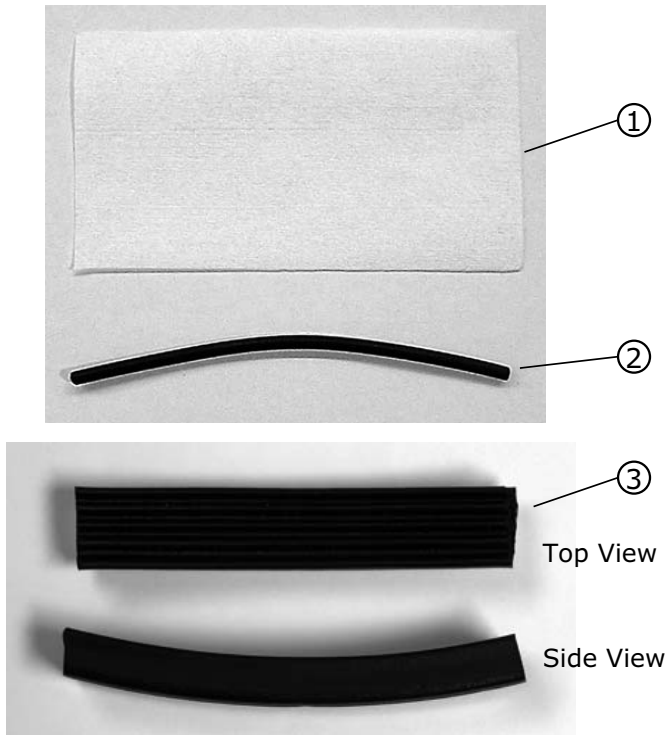

Item	Description	Part No.	Qty.
1	Synthetic Patch	22205368	1 package
2	Bead Cord	22150524	4
3	Needle Wipe	22151089	4

TOLERANCES UNLESS OTHERWISE SPECIFIED				GPD Global	
FRACTIONS	31/32	METRIC		NAME: Needle Cleaner Kit	
2 PLACE DECIMAL	±0.015	0.0 MM	±0.4MM	USED ON: (Grip Type - Synthetic Patch)	
3 PLACE DECIMAL	±0.015	0.000MM	±0.1MM	MATERIAL:	
ANGULARITY	±0.5°			HEAT TREAT: -	
RUNOUT	±0.003 T.I.R.			FINISH:	
DRAWN BY: MK			DWG SIZE	PART NUMBER	
CHECKED BY:			DO NOT SCALE DRAWING	22295111	
DATE: 05/22/13			SCALE: N/A	REV: A	

Precision Fixture Setup - 22295560

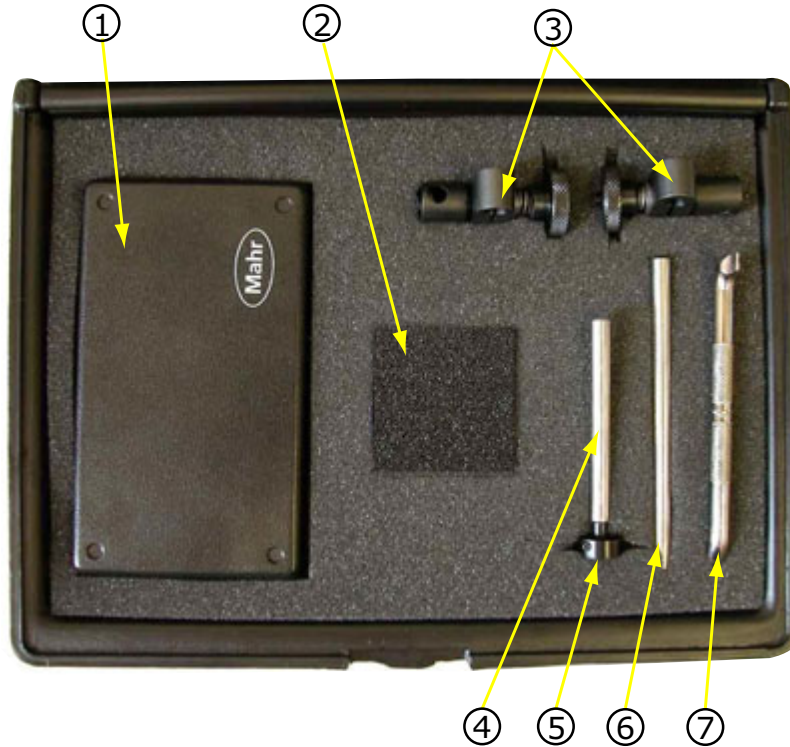

Revision Notes
 A 08/16/04 Original issue.
 B 06/18/09 Change 22215004 to 10/3977.
 C 02/04/14 Add 22215004, line stock.

Item	Description	Qty	P/N
1	Dial Indicator	1	10/3978
2	Recessed Space for Jig	N/A	Jig part number varies with fixture specifications. Jig ships with fixture but can be stored in this kit
3	Swivel Joint Clamps	1 each	10/3980 and 10/3983
4	Linkage Shaft	1	22205692
5	Linkage Shaft Base	1	22205691
6	Linkage Shaft Crossing	1	22205693
7	Flat Blade Screw Driver	1	10/3977
8	Offset Screw Driver *	1	22215004
9	Sockethead Cap Screws *	2	Line Stock

* Not shown

TOLERANCES UNLESS OTHERWISE SPECIFIED FRACTIONS ±1/32 METRIC 2 PLACE DECIMAL ±0.015 0.0 MM ±0.4MM 3 PLACE DECIMAL ±0.005 0.00MM ±0.1MM ANGULARITY ±0.5° RUNOUT ±0.003 T.I.R.		GPD Global NAME: Precisor Fixture Setup Kit USED ON: MATERIAL: HEAT TREAT: - FINISH:	
DRAWN BY: CHECKED BY: MK DATE: 06/18/09		DWG SIZE: DO NOT SCALE DRAWING SCALE: N/A	
		PART NUMBER: 22295560 REV: C	

NCM Wipe Replacement Kit - 22295608

Revision Notes
A Original issue.

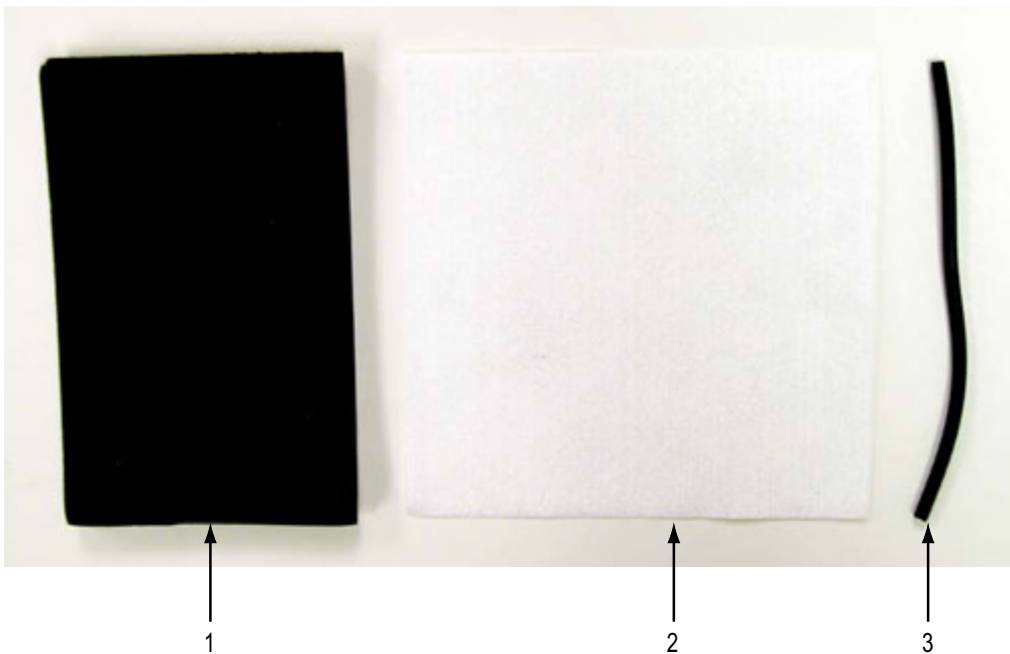

Item	Description	Part No.	Qty
1	Backing Pad	22205793	1 pkg
2	Pad Cover	22205794	1 pkg
3	Bead Cord	22150524	2

TOLERANCES UNLESS OTHERWISE SPECIFIED			
FRACTIONS	±1/32	METRIC	
2 PLACE DECIMAL	±0.015	0.0 MM	±0.4MM
3 PLACE DECIMAL	±0.005	0.00MM	±0.1MM
ANGULARITY	±0.5°		
RUNDUT	±0.003 T.I.R.		
		DWG. SIZE	

GPD Global	
NAME: NCM Wipe Replacement Kit	
USED ON:	
MATERIAL:	
HEAT TREAT:	-
FINISH:	
PART NUMBER	REV
22295608	A

Fluid Pressure Sensor Calibration Kit - 22893033

Item	Description	Part No.	Qty	Item	Description	Part No.	Qty
1A	Fitting, quick disconnect	10/1547	1	6	Digital air pressure gauge	5100-0160	1
1B	Fitting, air cap coupling insert	2675-0180	1	7	Hose, black, 1/4"	10/1683	50"
2	Hose, blue, 6 mm	10/4622	36"	8	Syringe air cap, 30 cc	10/1542	1
3	Cable	22998034	1	9	Syringe, 30 cc	10/1512	1
4	Fitting, tee	2675-0251	1	10	3-way stop cock	2625-0020	1
5	Fitting, straight, 6 mm to 1/4"	2675-0003	1				

Revisions	
A	06/24/2020 Original issue.

Two Configurations: Item 1A/1B variable

Use on: DS Series and MAX Series Dispensing Systems

Use on: Advanced FPC Real Time Controller, "your" controller, or as Stand-alone Kit

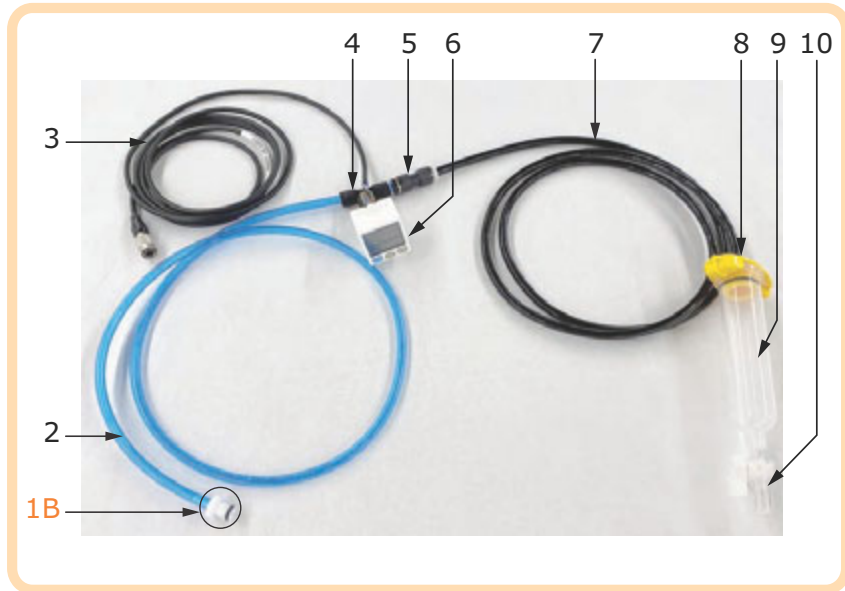
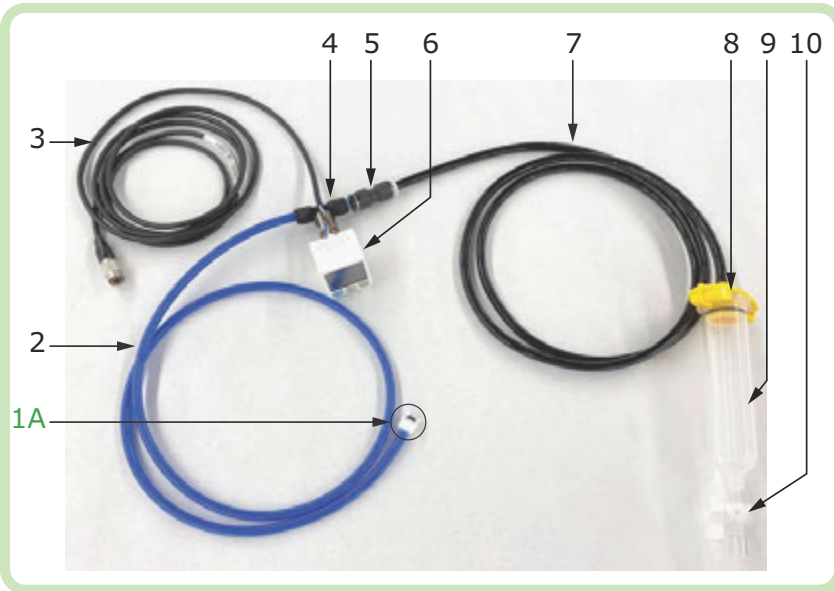

NOTE:
For kit installation and usage instructions, refer to the sensor calibration procedure in the manual for the controller equipment on which the kit is installed.

GPD Global® Precision Dispensing Systems				NAME: Fluid Pressure Sensor Calibration Kit	
TOLERANCES UNLESS OTHERWISE SPECIFIED				USED ON:	
FRACTIONS	±1/32	METRIC		MATERIAL:	
2 PLACE DECIMAL	±0.015	0.0 MM	±0.4MM	HEAT TREAT: -	
3 PLACE DECIMAL	±0.005	0.00MM	±0.1MM	FINISH:	
ANGULARITY	±0.5°			PART NUMBER	
RUNDOUT	±0.003 T.I.R.			REV	
DRAWN BY: MK				22893033	
CHECKED BY:				DO NOT SCALE DRAWING	
DATE: 06/24/2020				SCALE: N/A	
				A	