

GPD MicroCell™

SYSTEM INTRODUCTION



- Compact Footprint
- Rock-Steady Unibody Frame
- Functional Workarea
12" x 12" (305 mm X 305 mm)
- Ergonomic Monitor/Controls Arm
- 2 Valve/Tool Capability
- ClearVu™ Programmable Zoom-&-Focus Vision
- Accuracy of ± 0.001 " (0.025 mm)
- Micro-Dot Valve Ready
- Live Process Viewing Cameras & Monitor

The MicroCell™ is the newest member of the MAX family of dispense systems. The MicroCell, in either a stand-alone or inline configuration, incorporates specific features designed for precise, MicroVolume dispensing. At the heart of the MicroCell is the exclusive, GPD Global® unibody frame. The unibody frame creates a stable platform for precise and repeatable movement – exactly the type of movement required for precision applications.

To align complex substrates, the MicroCell utilizes ClearVu™ Vision. ClearVu™ Vision is a programmable zoom and focus camera designed to let the operator view micro alignment points on a variety of surfaces and at multiple levels. To accommodate MicroVolume dispensing, the MicroCell is outfitted with the Micro-Dot valve.

The Micro-Dot valve is an encoder-controlled valve with 57,000 counts per single revolution. For any given dot, valve motion is controllable down to the acceleration, deceleration, speed in counts per second, and number of counts. To verify dot diameter, the ClearVu™ Vision camera has been equipped with the ability to inspect dispensed dots and confirm whether or not the dots are within

specification. If a dispensed dot is found to be outside of specification, the system will flag the operator for assistance.

Ordinarily, viewing the dispense process for a MicroVolume application is nearly impossible when the system is in run mode. On the MicroCell, however, an optional process view camera is able to display the dispense process as it is being done at the dispense tip. Live video from the operating valve is displayed on a process view monitor where the operator can easily view the process.

The system is easily operated from the side mount control arm, exclusive to the MicroCell dispense system. The side mount arm gives the operator a comfortable and ergonomic point from which to work.

These features, coupled with the host of standard MAX Series features make the MicroCell the key to your precision processing needs: automatic XYZ calibration (no operator intervention required), needle and nozzle cleaners, computer-controlled syringe air pressure, Contour Mapping™, and FLOWare® operating software.

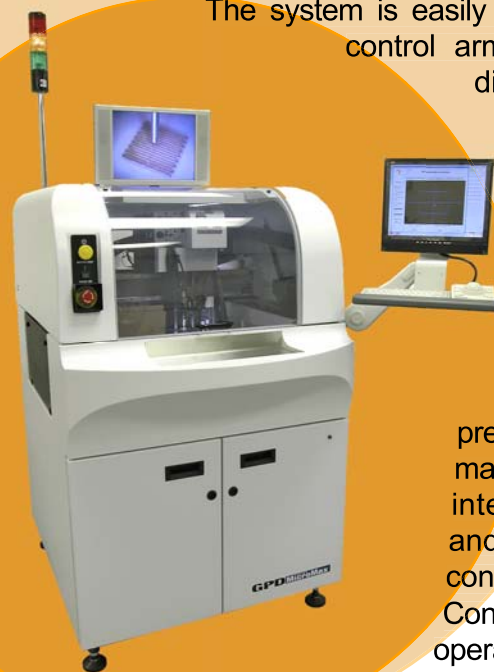

GPD Global®

Standard Features

- ClearVU™ Vision (programmable zoom & focus)
- Ergonomic, Side-Mount Monitor Arm
- Live Process-Viewing Camera & Overhead Display
- Red/Blue Illuminator
- Needle Cleaner
- Auto X, Y, Z Calibration
- 2 Valve Capability
- Tool-less Taper-Lock™ Mounting Hardware
- Computer Controlled Syringe Pressure
- FLOWare® Operating Software
- Network Communications

Power

MicroCell™ SA, MicroCell™ IL

120 Volts or 230 Volts AC frequency 50-60 Hz
Maximum 10 amps @ 120 Volts or 5 amps @ 230 Volts

GPD Global recommends use of dedicated, external circuit breaker/fusing. Alternately, use properly rated branch fusing.

Air

Pressure (clean & dry air) . . . 80 psi (552 kPa)

Flow rate (maximum) - add flow for each system present:

machine 4 CFM @ 87 psi (113 l/min @ 600 kPa)

optional vacuum system . . . 4 CFM @ 50 psi (113 l/min @ 345 kPa)

Air fitting thread* 1/4" NPT

*(customer supplies connection hardware)

Ventilation

Exhaust port* 4" (101.6 mm)

*(customer supplies ducting to exhaust port)

Ventilation flow rate 250 CFM (7,079 l/min) per port

Crating Specifications

Weight, crated 2250 lbs (1021 kg)

Dimensions, crated 51" W x 63" D x 72" H
(130 cm W x 160 cm D x 183 cm H)



Headquarters

611 Hollingsworth Street, Grand Junction, CO 81505
tel: +1.970.245.0408 • fax: +1.970.245.9674 • request@gpd-global.com • www.gpd-global.com Rev 01/08

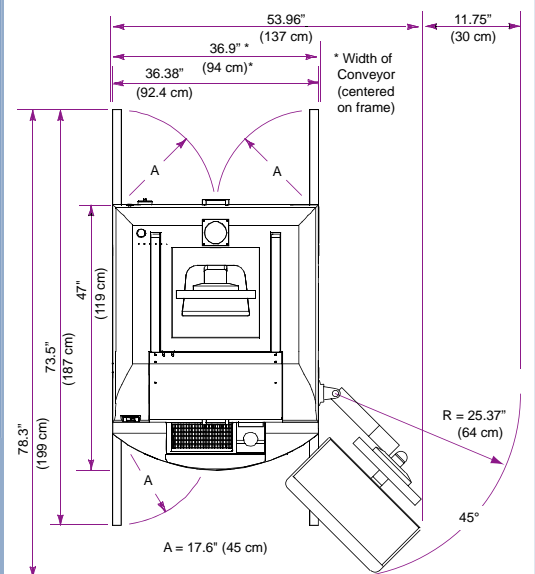
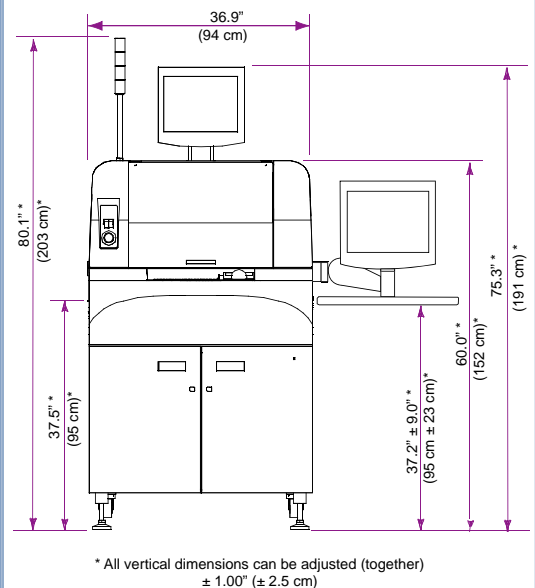
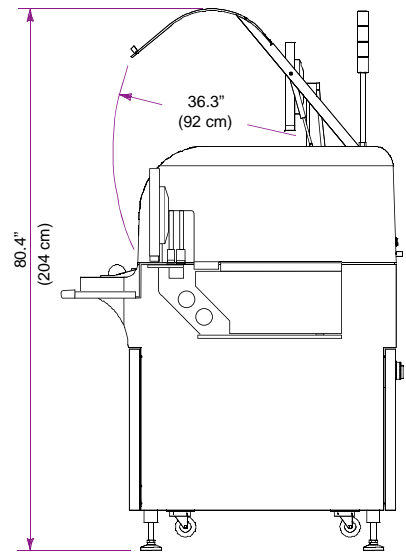

Standard direction of flow is Left-to-Right, however, Right-to-Left is configurable at time of order.